

Tools Recommended

IMPORTANT, RETAIN FOR FUTURE REFERENCE: READ CAREFULLY.

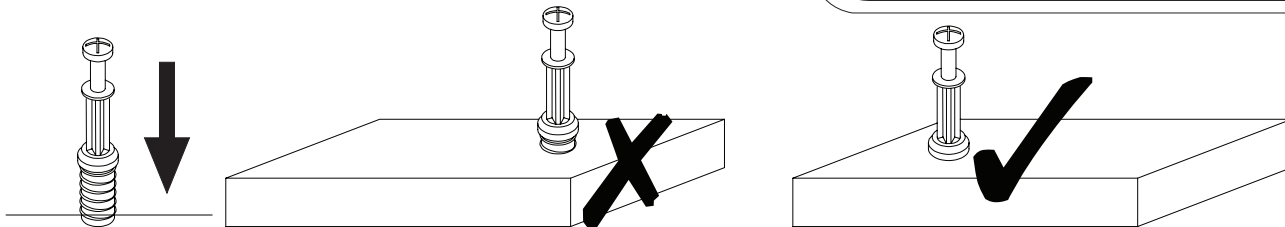

Tighten quickfit until shoulder is flush with panel. Do not overtighten or undertighten.

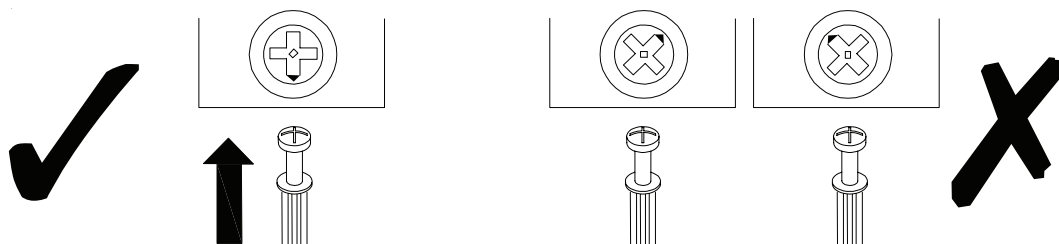

When fitting cam lock, ensure starting position is correct before you insert connecting quickfit.

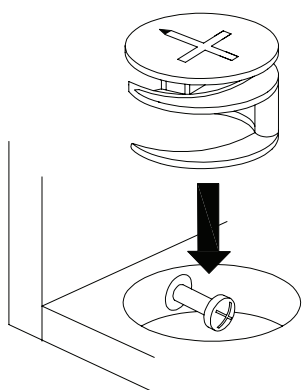

Quickfit head should be in the centre of the cam lock when the two panels are joined.
Cam lock should be inserted before quickfit.

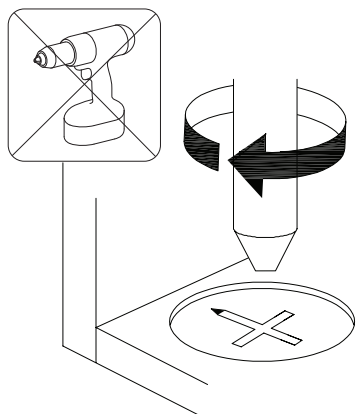

Turn cam lock clockwise to tighten.

1 x1

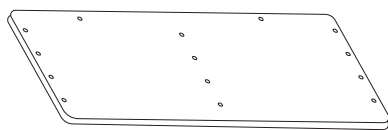

2 x1



3 x1

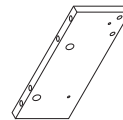

4 x1

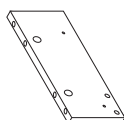

5 x1

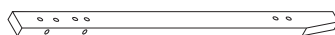

6 x1



7 x1

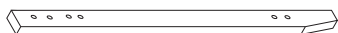

8 x1

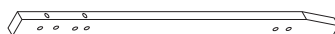

9 x2

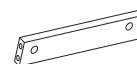

10 x1

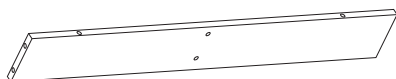

11 x1



12 x1

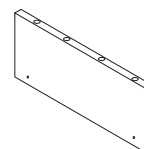

13 x2

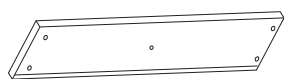

14 x2

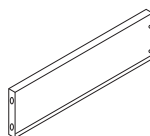

15 x2

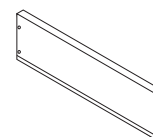

16 x2

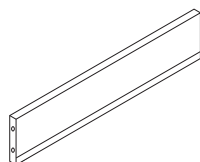



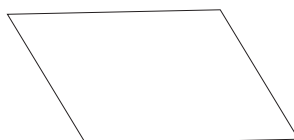





17 x2

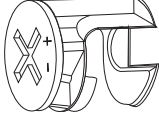

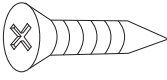
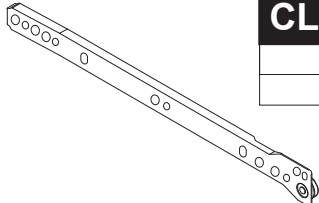
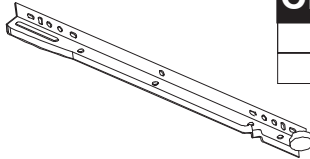
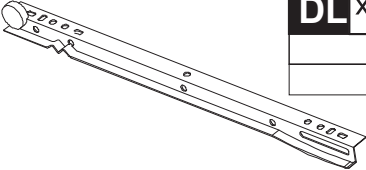
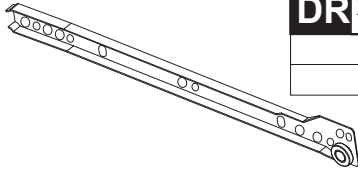
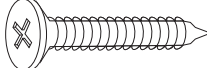
Do not confuse similar screws.

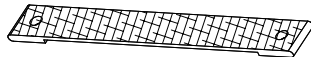
NOTE

 <p>A x2</p>	 <p>B x2 Ø4×16mm</p>	 <p>C x32 Ø6×35mm +1(spare)</p>
 <p>D x32 Ø15×10mm +1(spare)</p>	 <p>E x22 Ø8×30mm +1(spare)</p>	 <p>F x16 Ø3.5×12mm +1(spare)</p>
 <p>CL x2</p>	 <p>CR x2</p>	 <p>DL x2</p>
 <p>DR x2</p>	 <p>K x14 Ø4×35mm +1(spare)</p>	 <p>L x2</p>
 <p>M x2</p>	 <p>N x2 Ø4×12mm</p>	 <p>O x4</p>

Do not confuse similar screws. Do not tighten bolts fully until all parts are connected!

NOTE

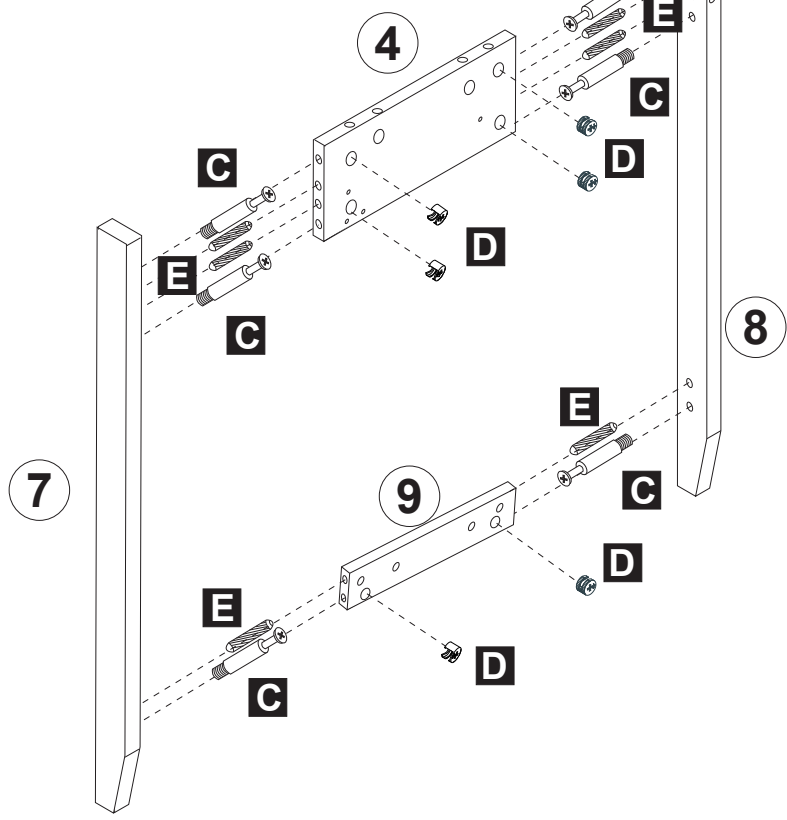
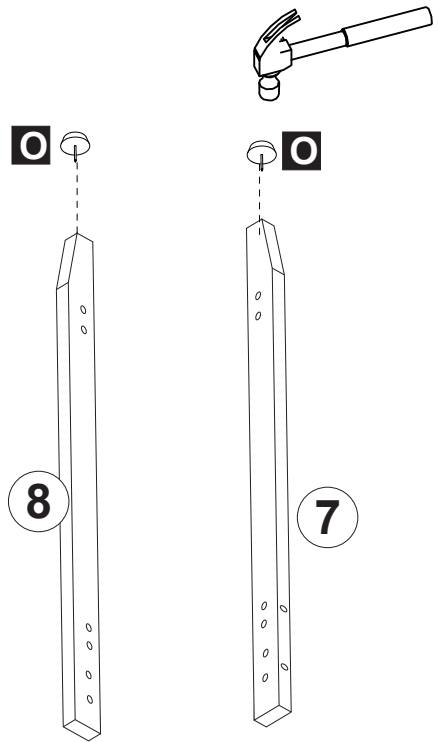
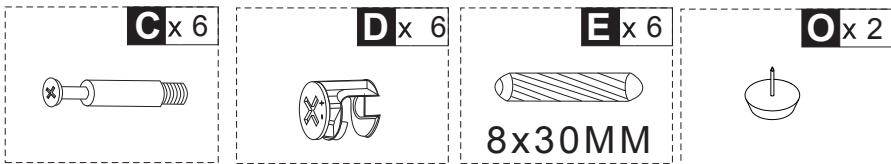
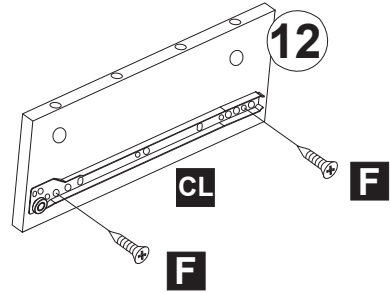
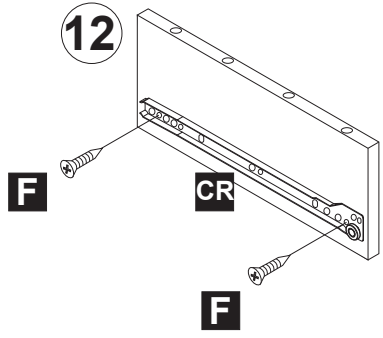
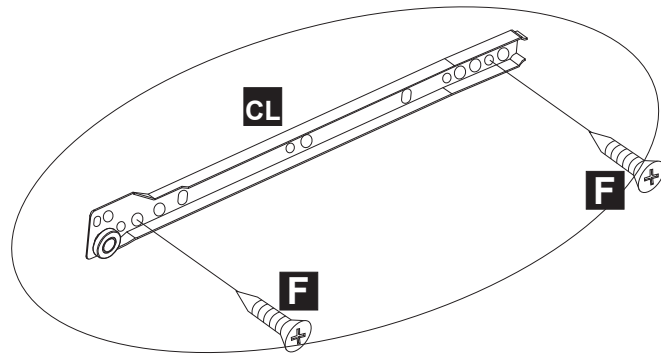
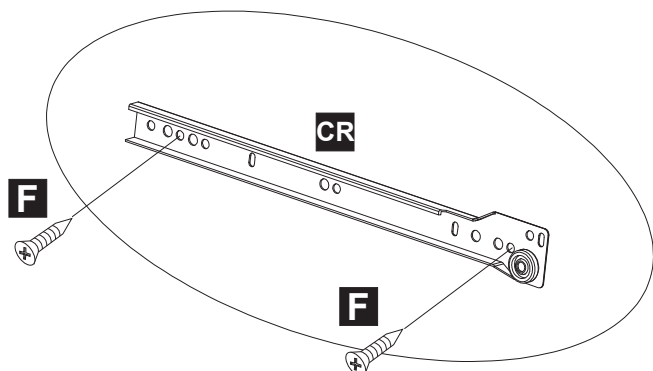
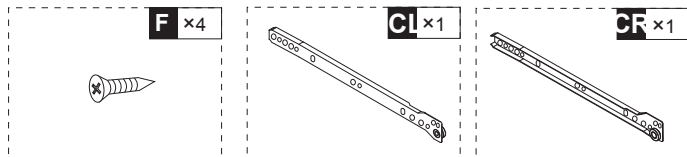

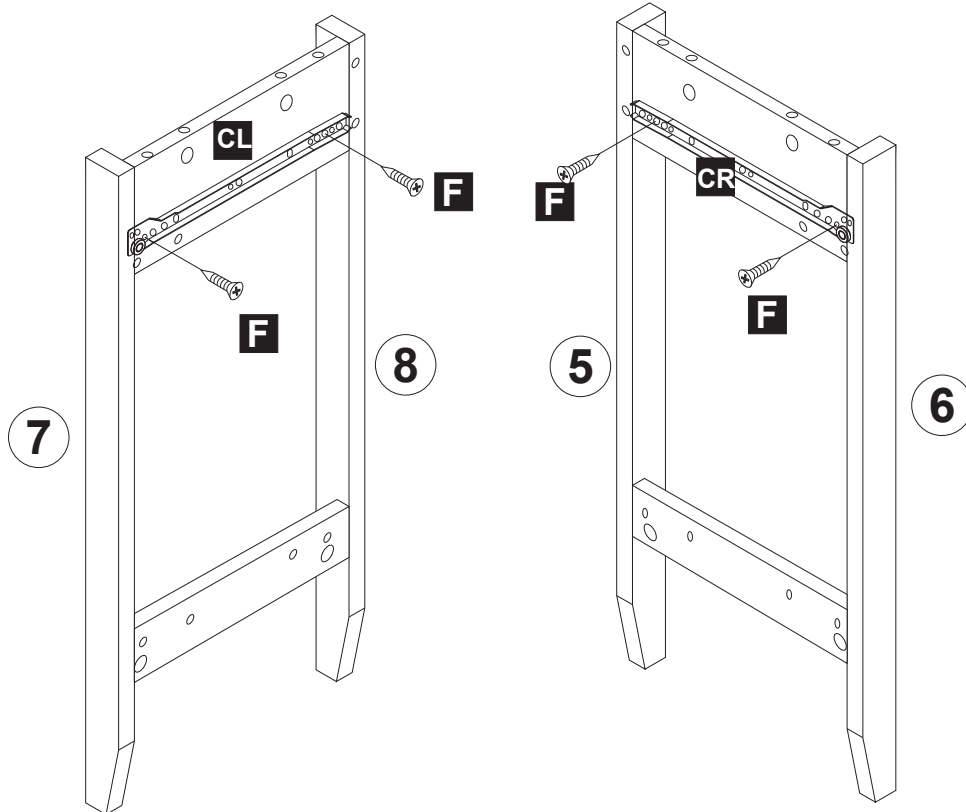
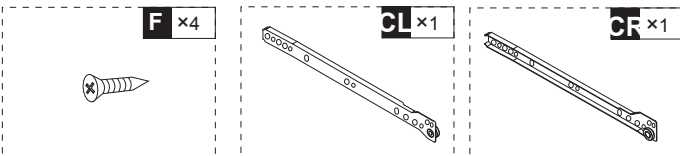
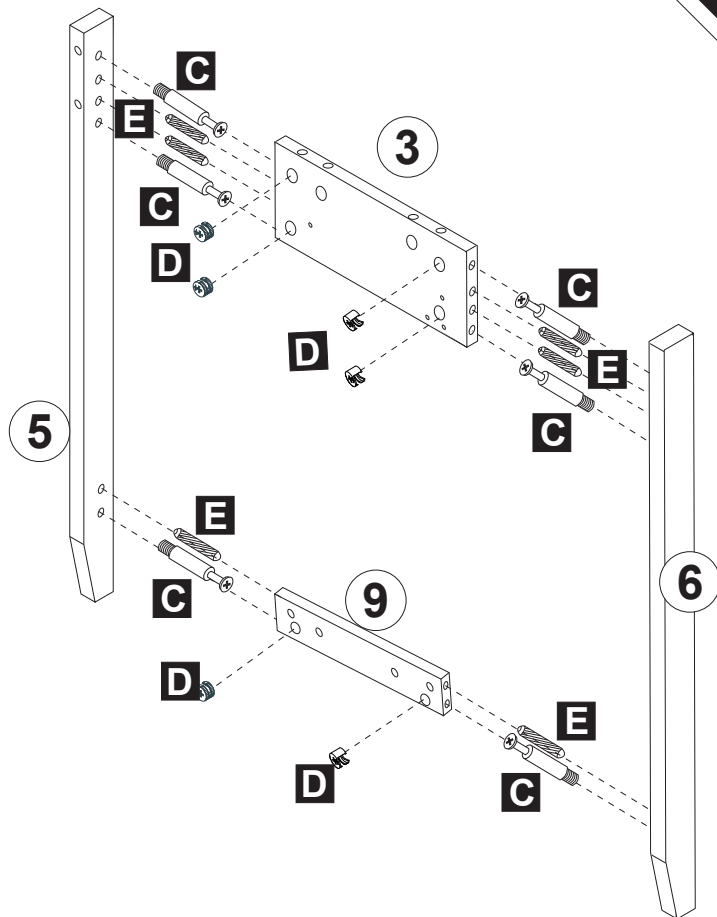
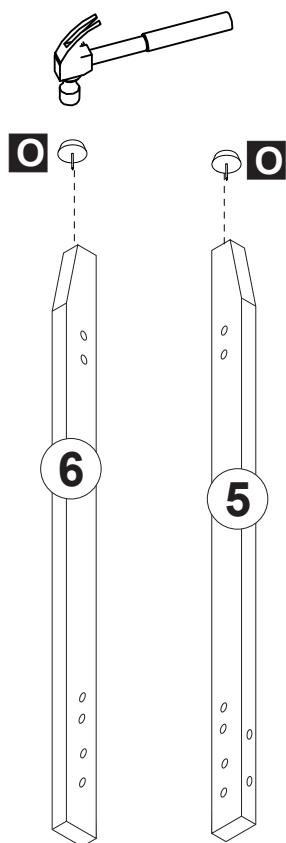
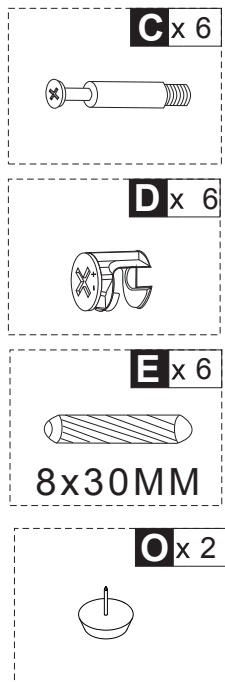

K x 4

4x35MM

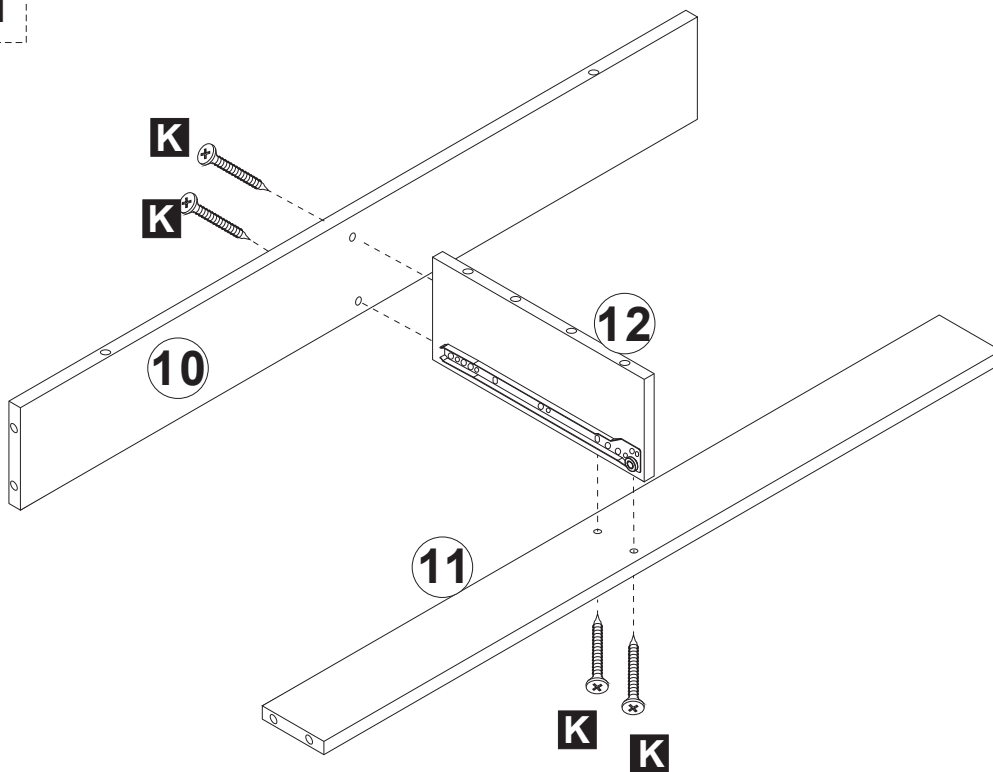

C x 6



D x 6



E x 2

8x30MM

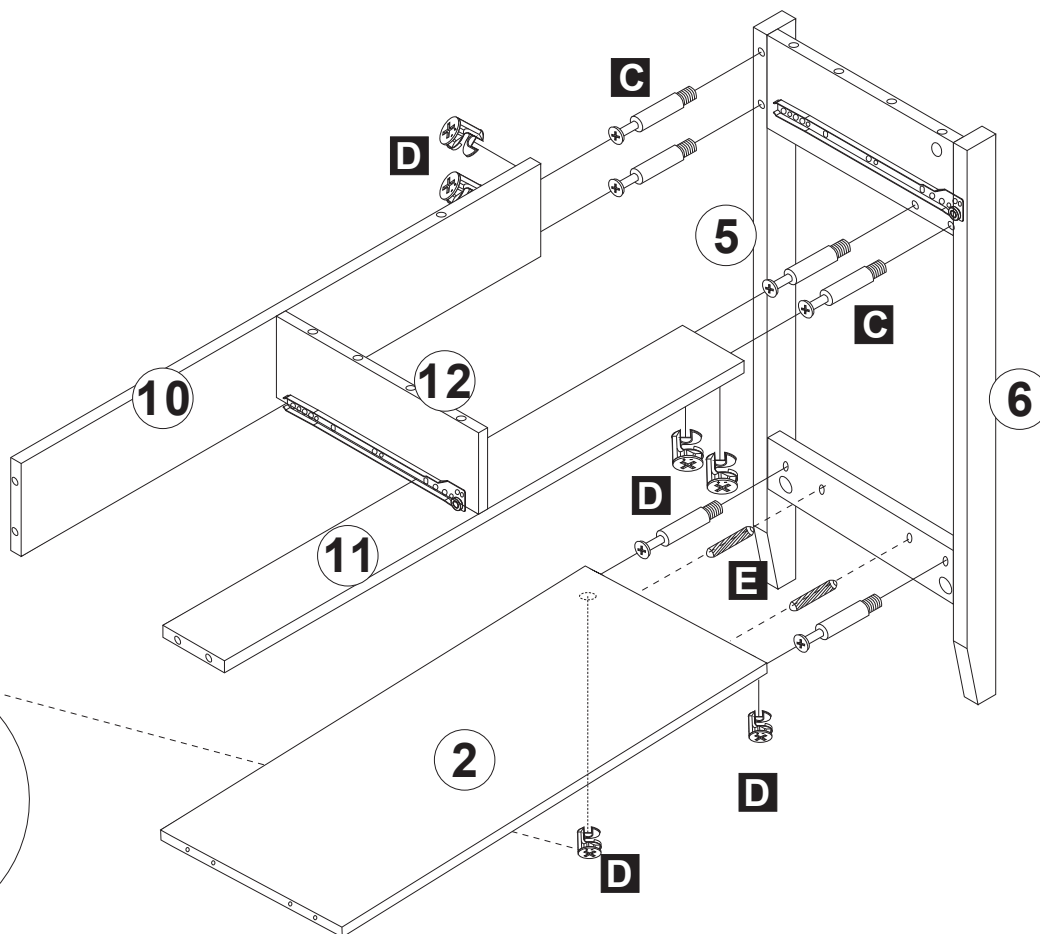

C x 6

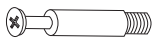

D x 6



E x 2



8x30MM

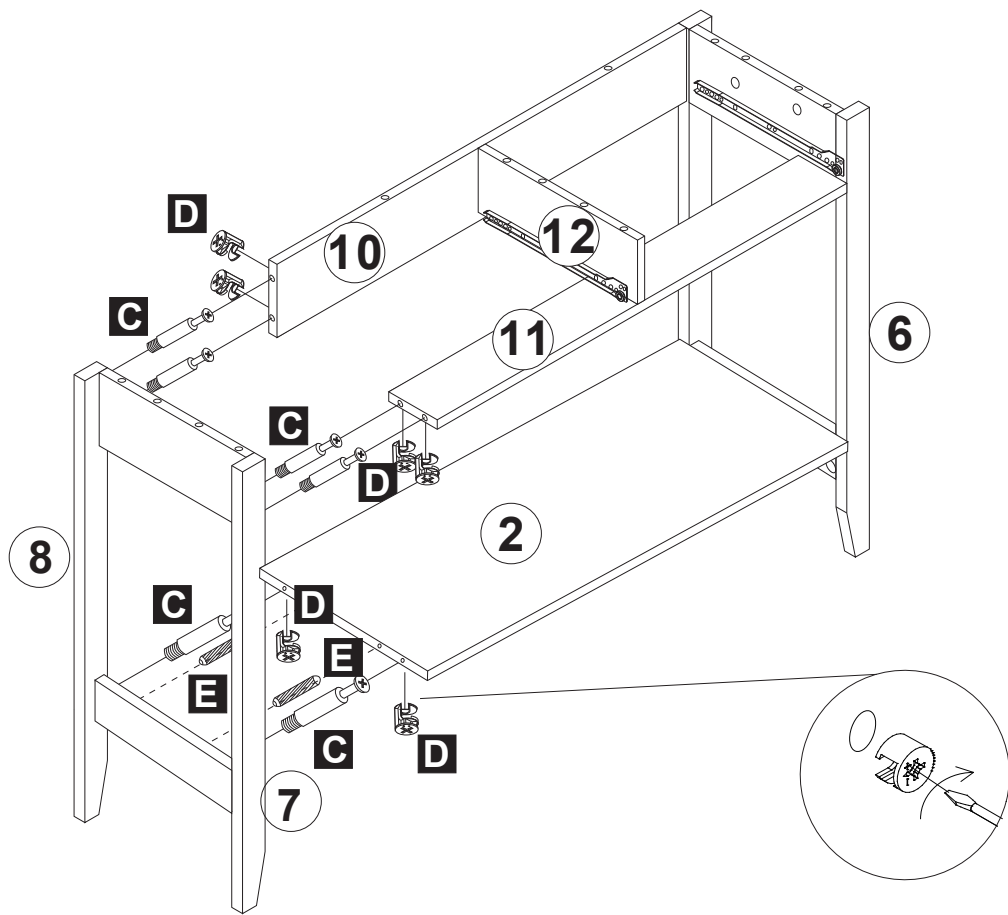

C x 8

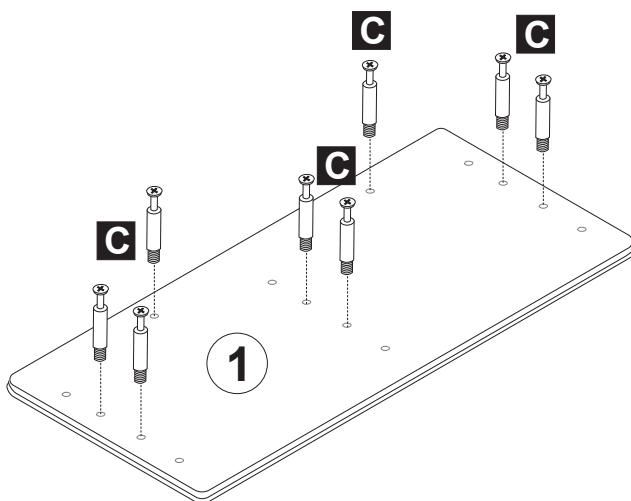
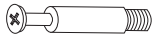

D x 8



E x 6



8x30MM

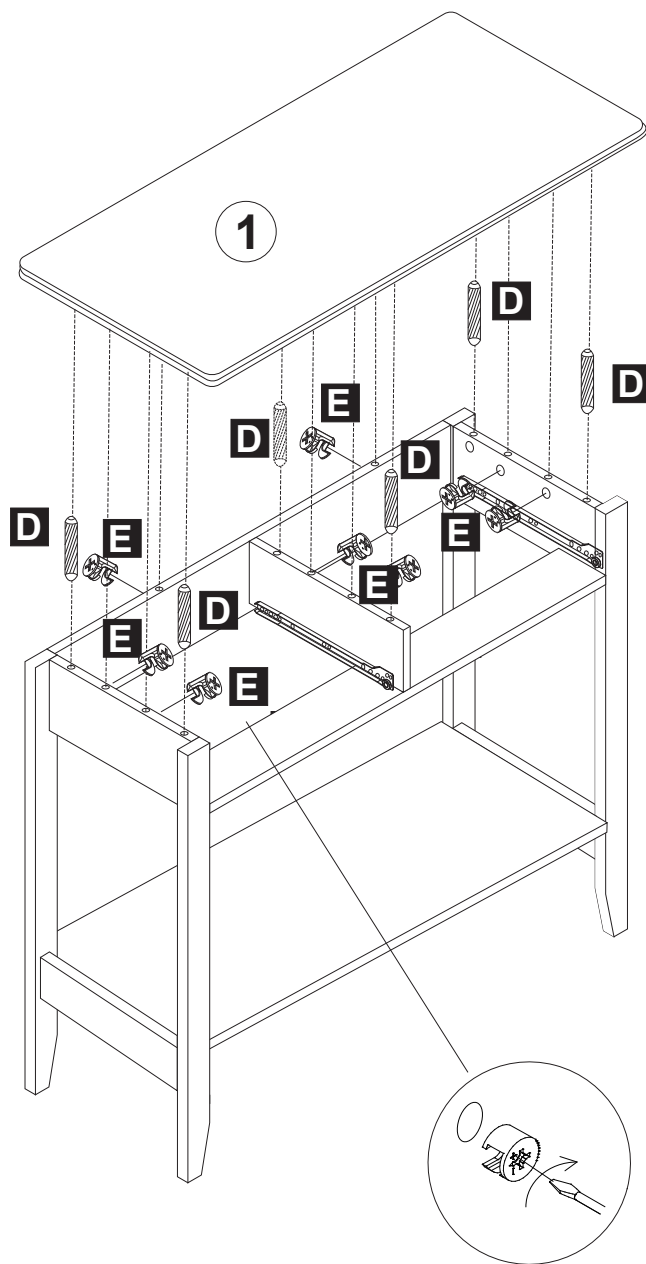

Mx 2



Nx 2

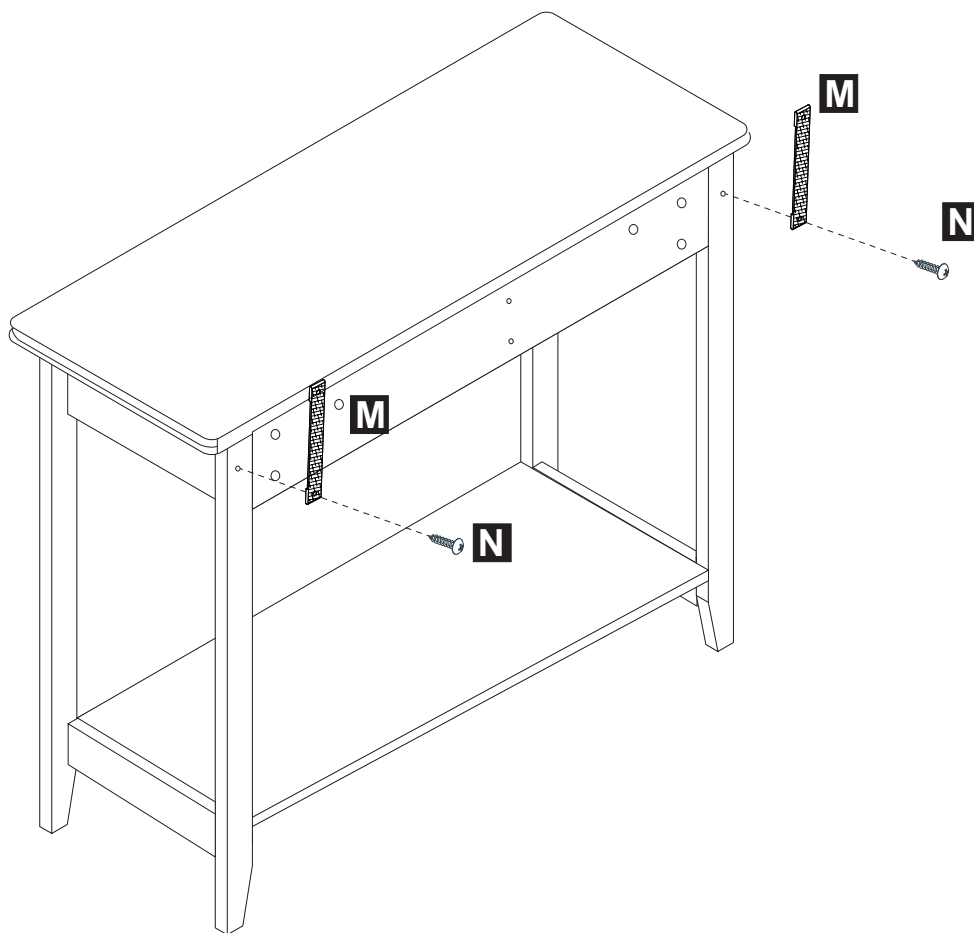

A x 2



K x 8



B x 2



4x18MM

C x 8



D x 8



F x 8

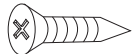

3x12MM

DR x 2

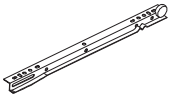

DL x 2

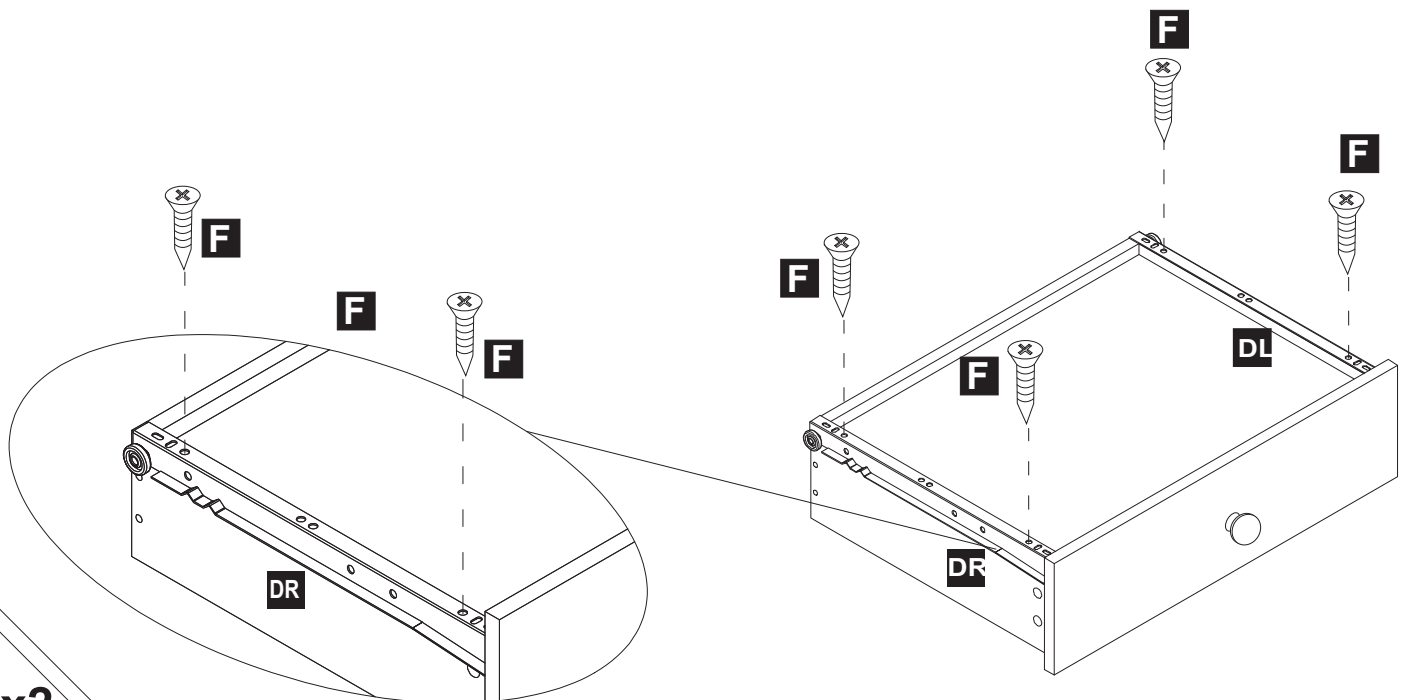
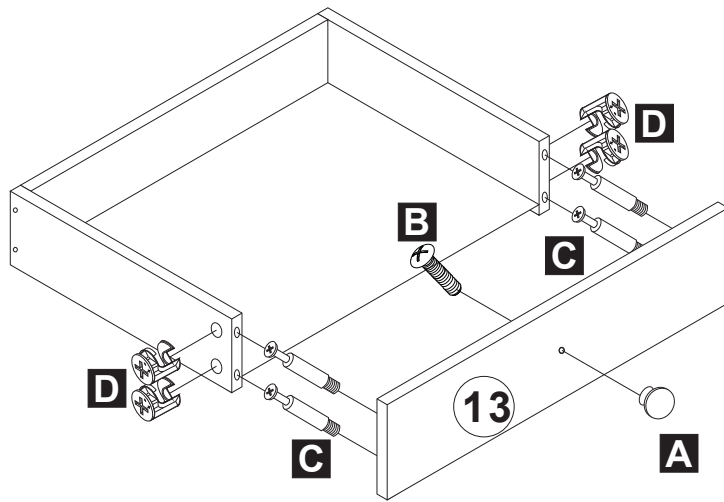
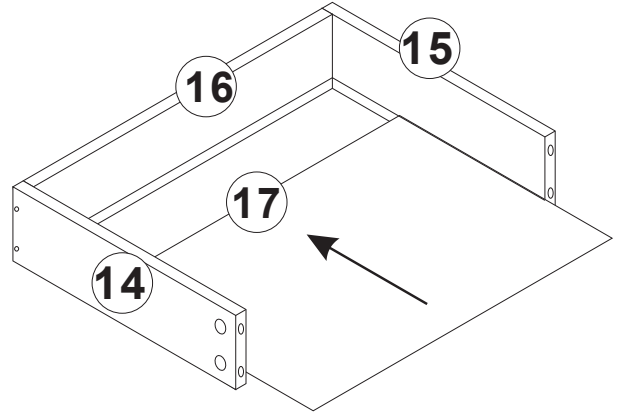
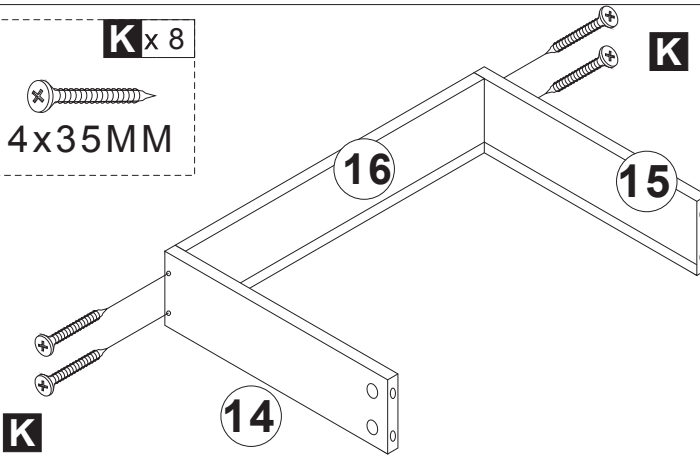
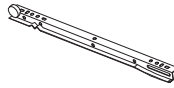

x2

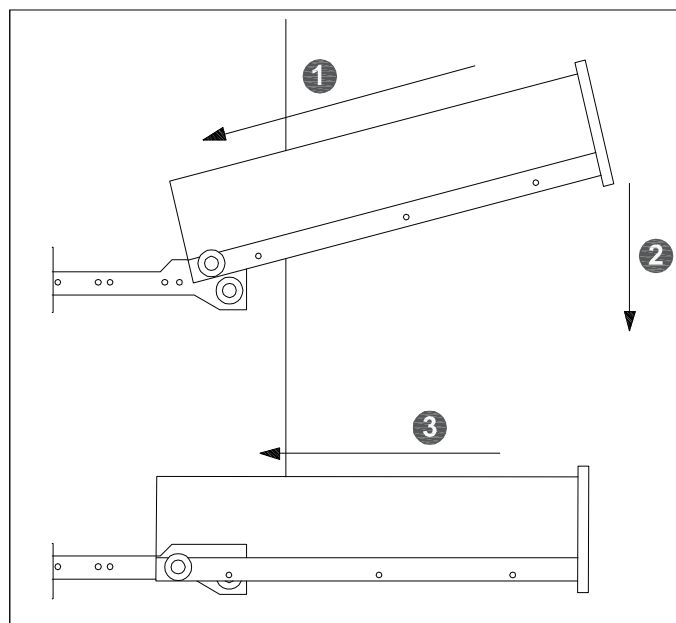
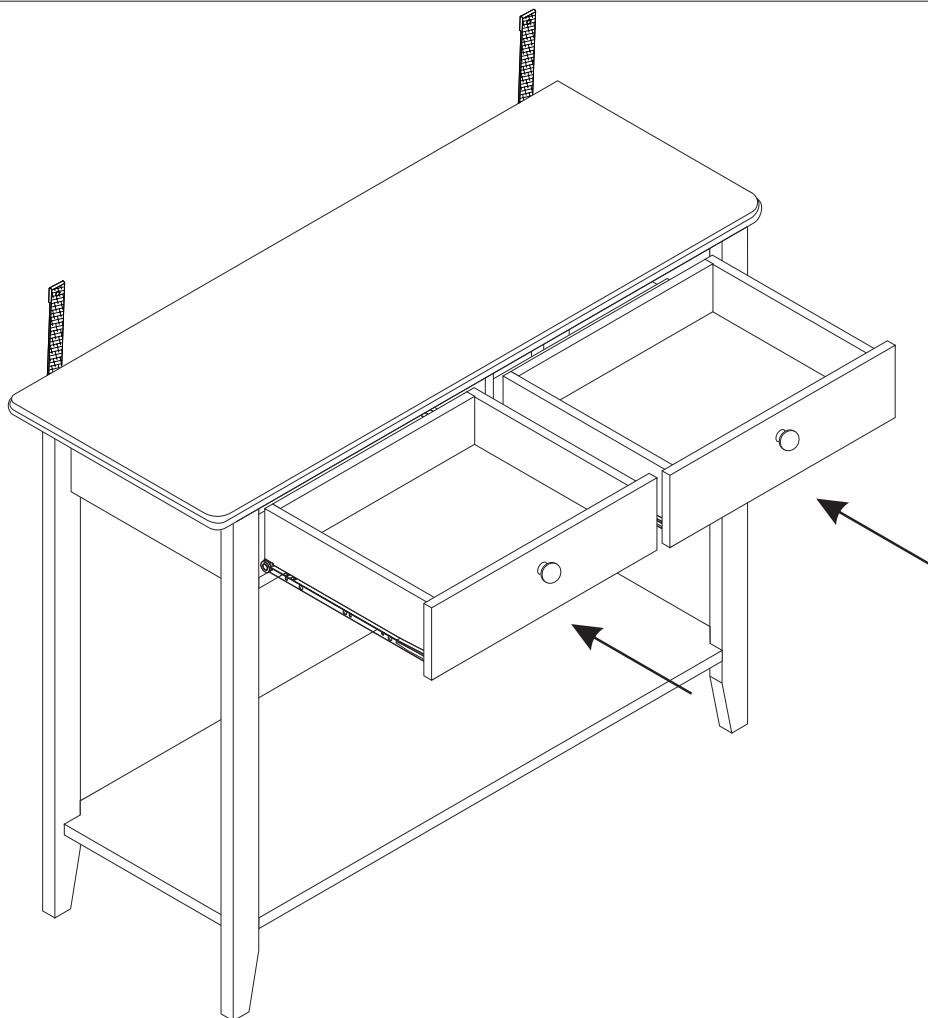

Be careful to push in the board when the both sides slide way been aligned.

K x 2



L x 2

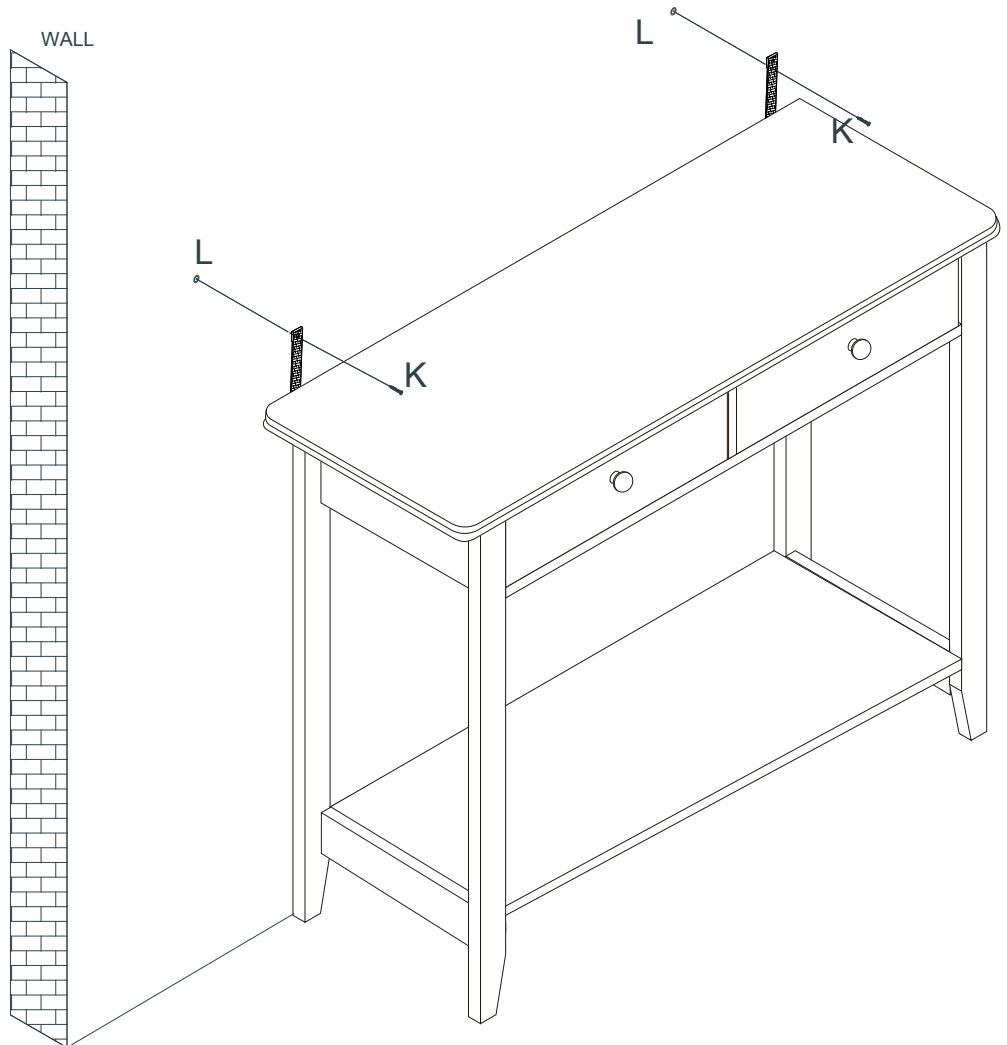

This is anti-dumping belt that fix the product to the wall and it can be used or not follow your needs.

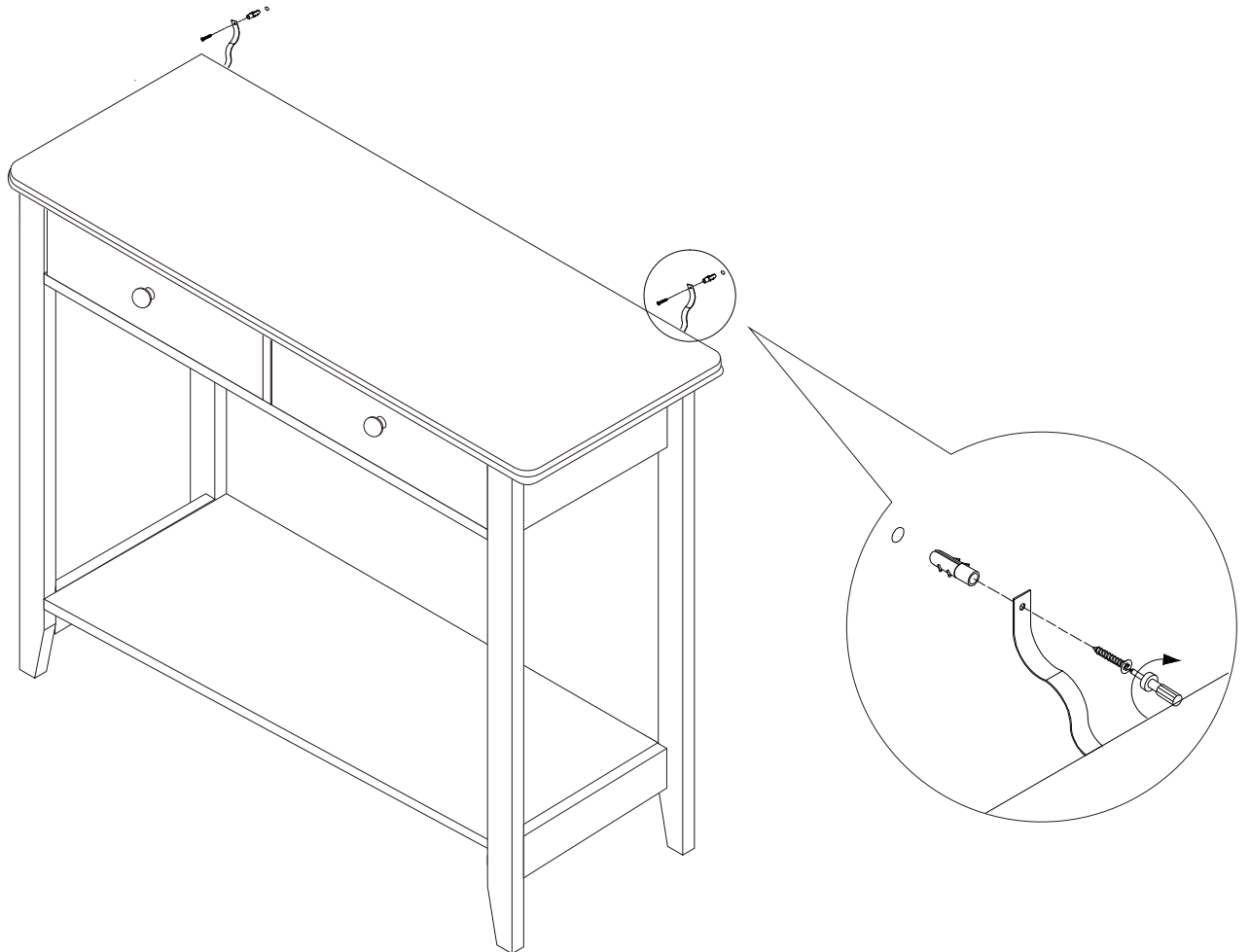

EN If it is a solid wall, please use expansion and self-tapping screws, if it is a wooden wall, only use self-tapping screws, please do not overtighten the screws