





Tools Recommended

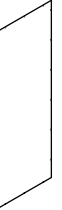
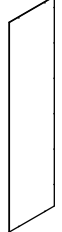

BOX-1/2

| NO. | PARTS | QTY |
|-----|---|-----|
| ② |  | 1 |
| ③ |  | 1 |
| ④ |  | 1 |
| ⑪ |  | 1 |
| ⑫ |  | 1 |
| ⑬ |  | 1 |
| ⑭ |  | 1 |

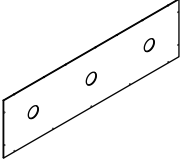
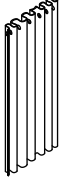
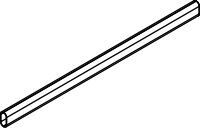
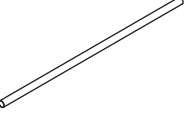
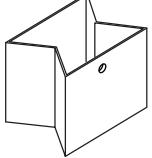
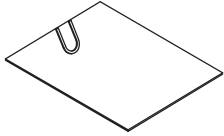
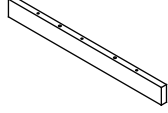
| NO. | PARTS | QTY |
|-----|---|-----|
| ⑮ |  | 1 |
| ⑯ |  | 1 |
| ⑰ |  | 1 |
| ⑱ |  | 1 |
| ⑲ |  | 3 |
| ⑳ |  | 3 |
| ㉑ |  | 1 |

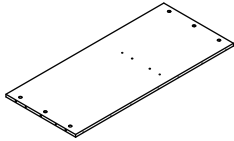
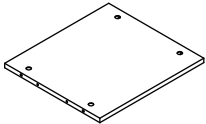
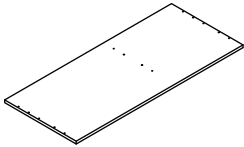
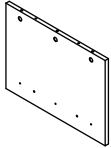
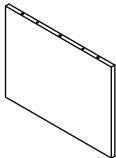
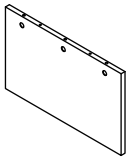
BOX-2/2

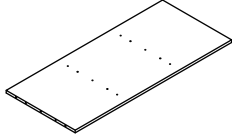
| NO. | PARTS | QTY |
|-----|---|-----|
| ① |  | 1 |
| ⑤ |  | 2 |
| ⑥ |  | 1 |
| ⑦ |  | 1 |
| ⑧ |  | 1 |
| ⑨ |  | 2 |

| | | |
|---|---|---|
| ⑩ |  | 1 |
|  <p>Hardware Kit</p> | | |

USING CAM LOCK AND QUICKFIT

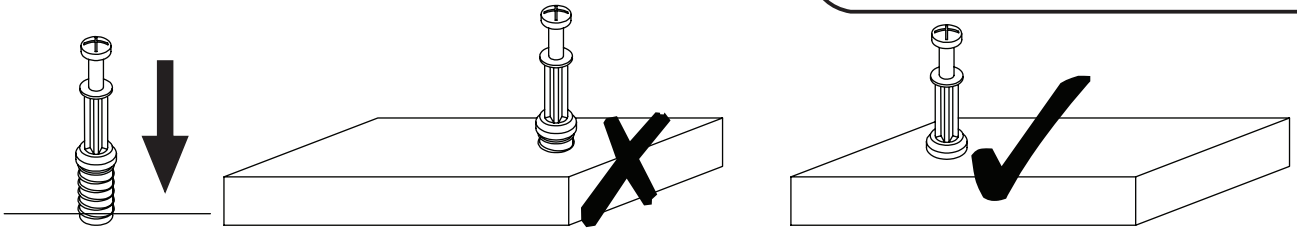

Tighten quickfit until shoulder is flush with panel. Do not overtighten or undertighten.

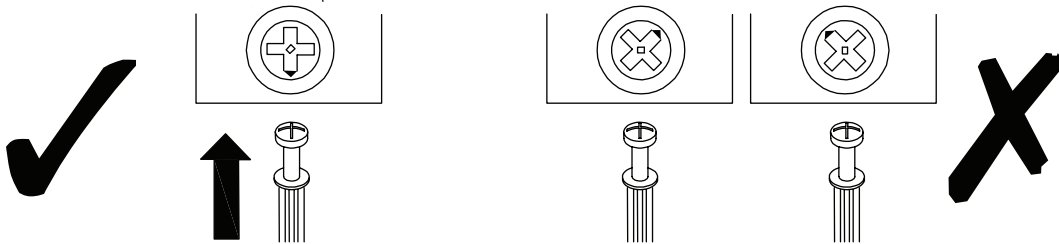

When fitting cam lock, ensure starting position is correct before you insert connecting quickfit.

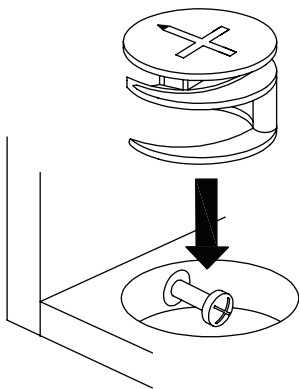

Quickfit head should be in the centre of the cam lock when the two panels are joined.
Cam lock should be inserted before quickfit.

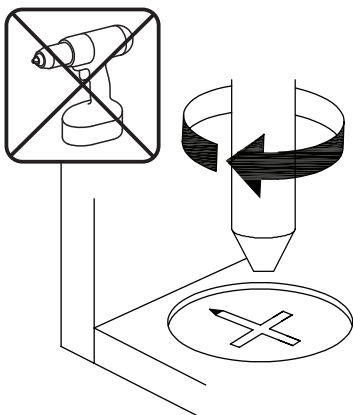

Turn cam lock clockwise to tighten.

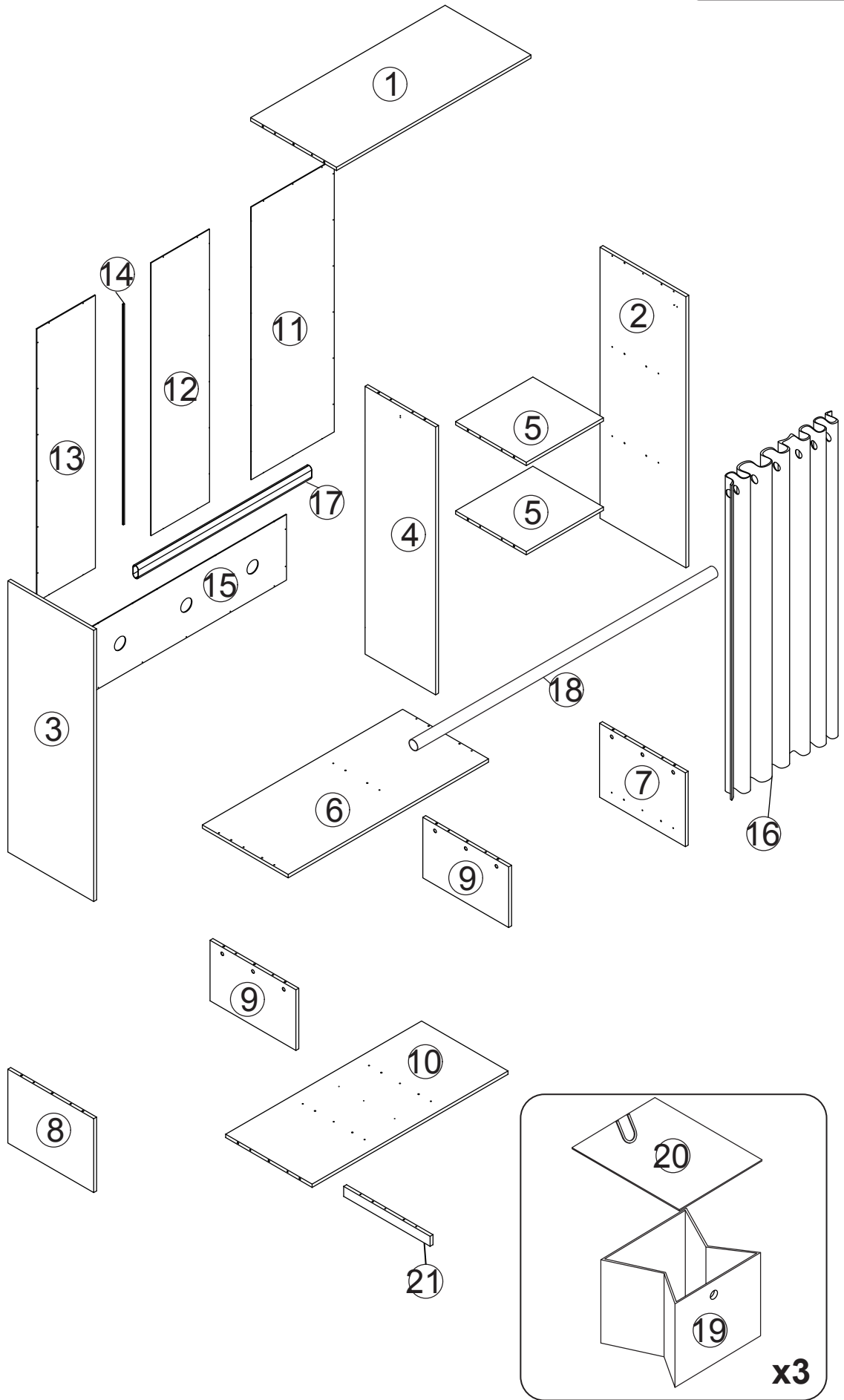

PARTS

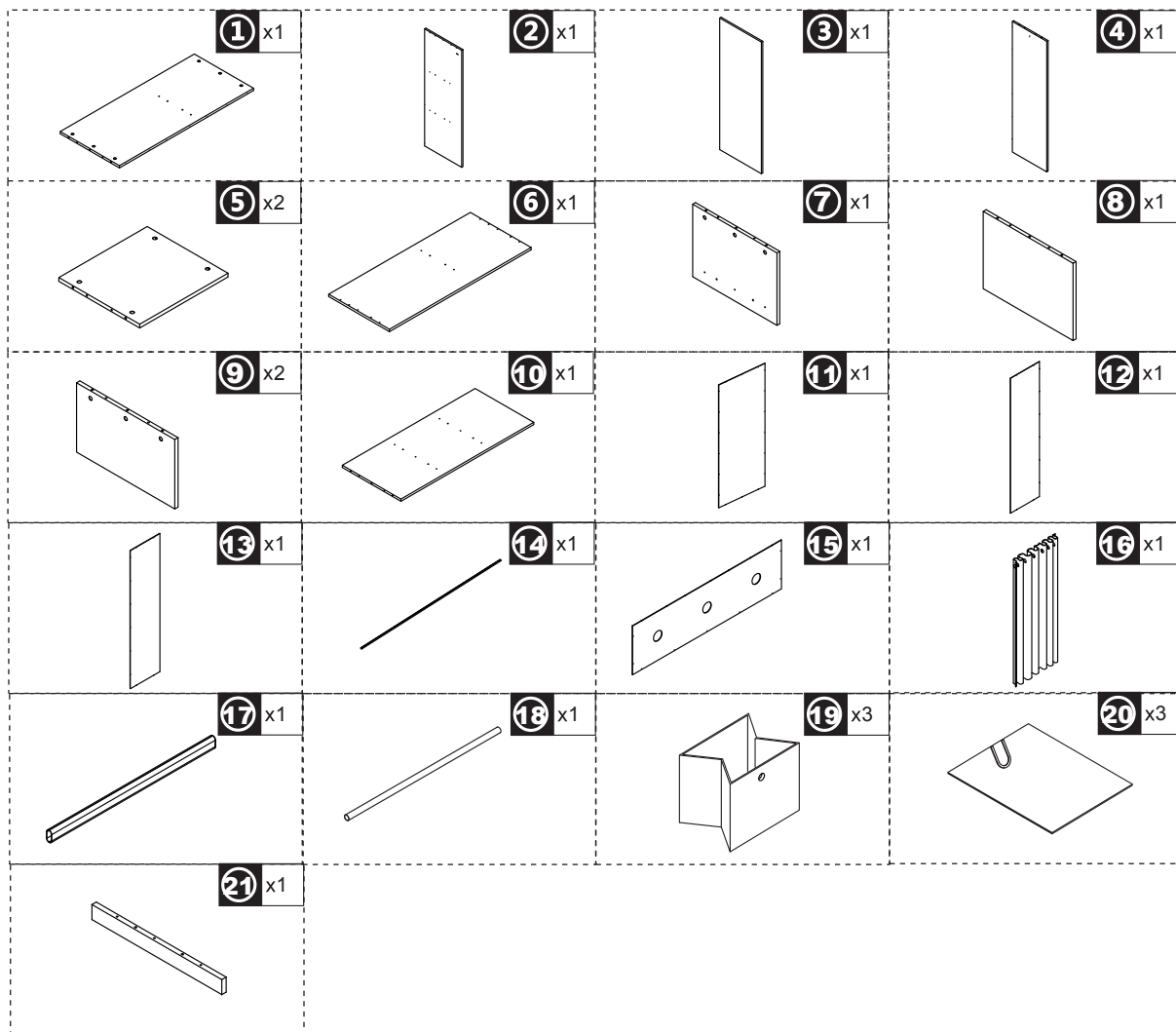

HARDWARE

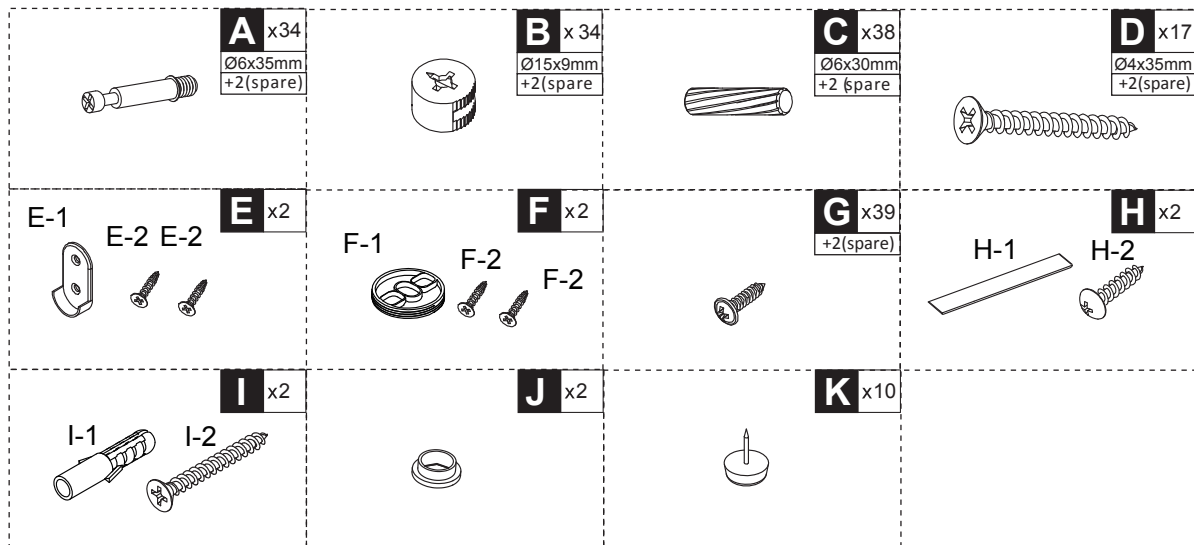

Do not confuse similar screws.

NOTE

A x6



K x10

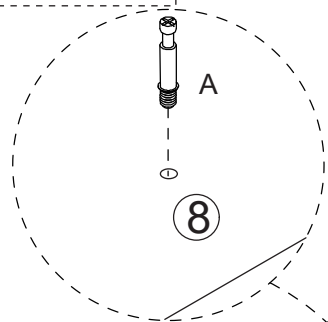

8

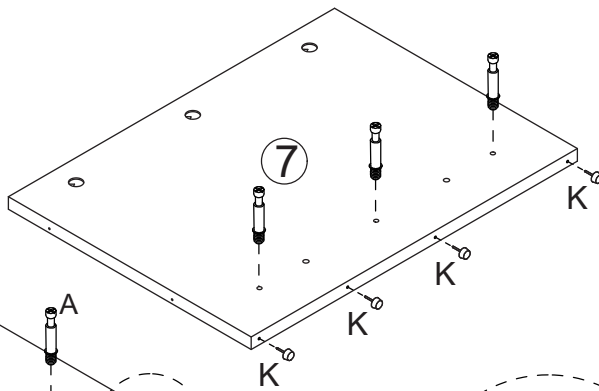
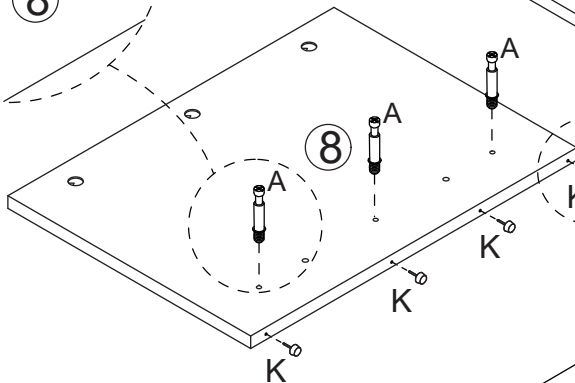

7

21

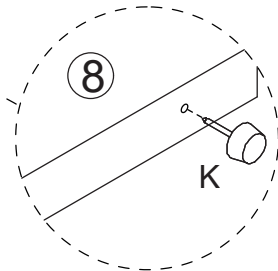
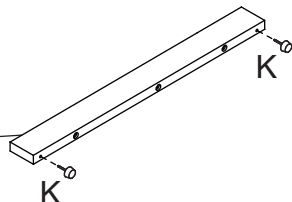

8

B x3



C x2

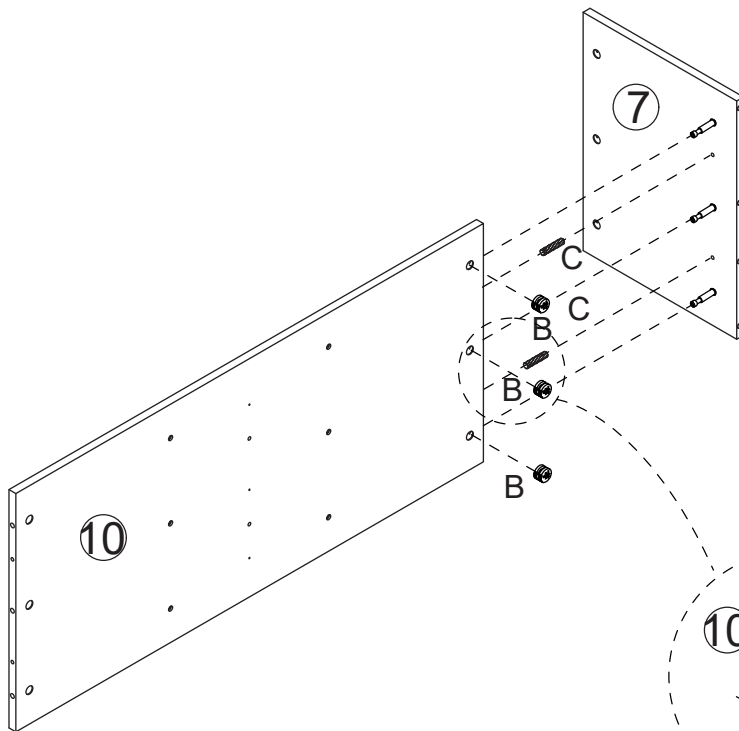

10

7

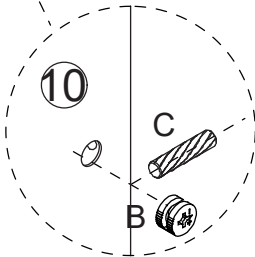

10

C

B

B x3



C x2

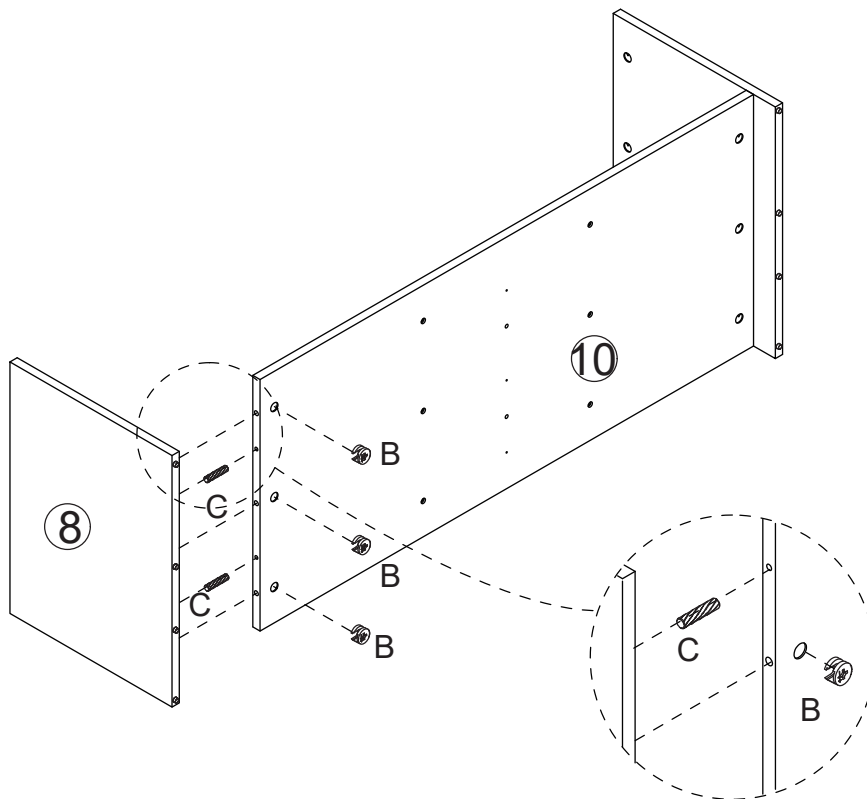

C x4



D x6

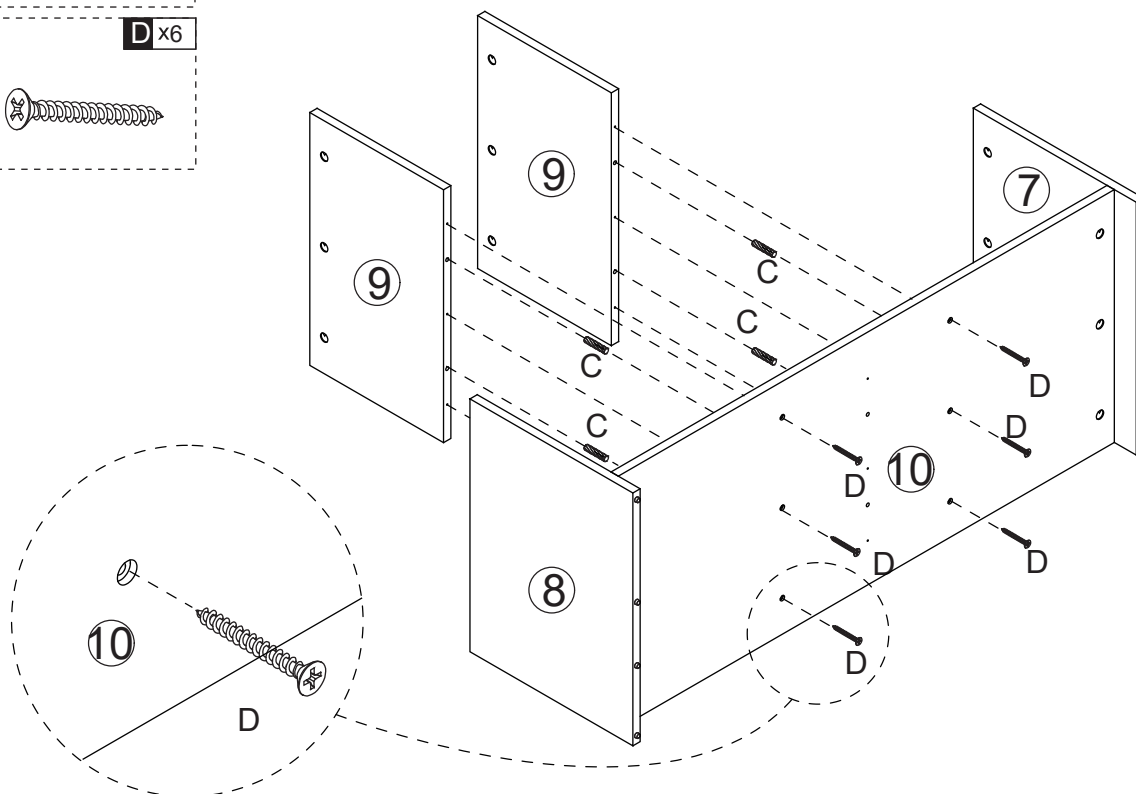

C x2



D x3

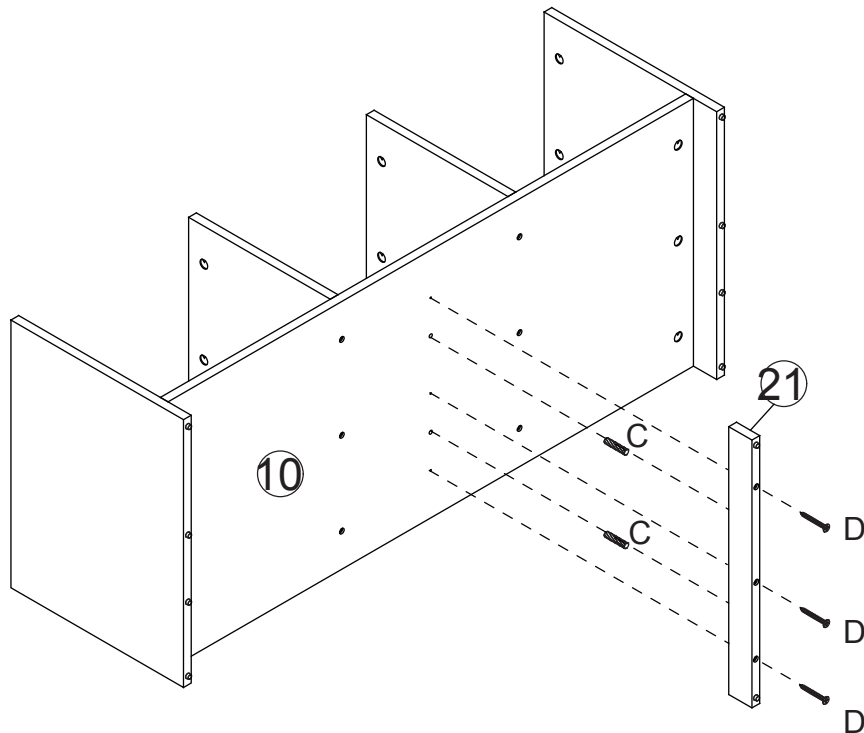

A x11



E x1



F x1

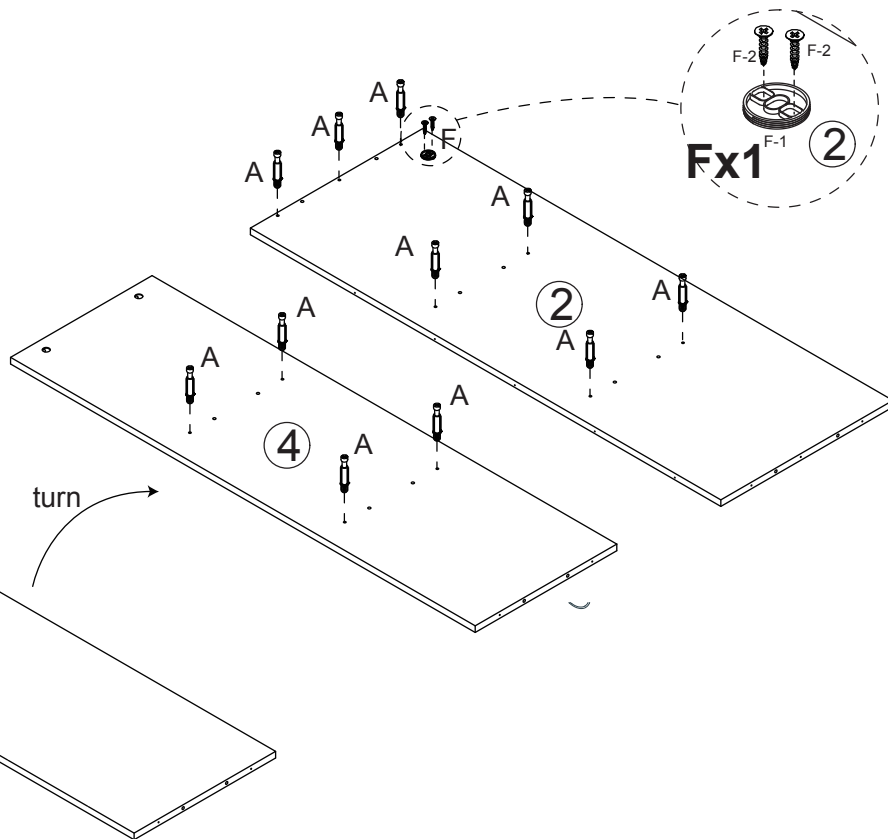

turn

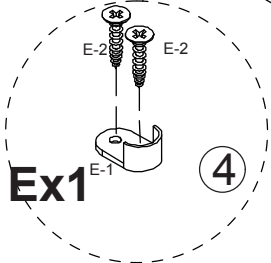

Ex1

B x4



C x4

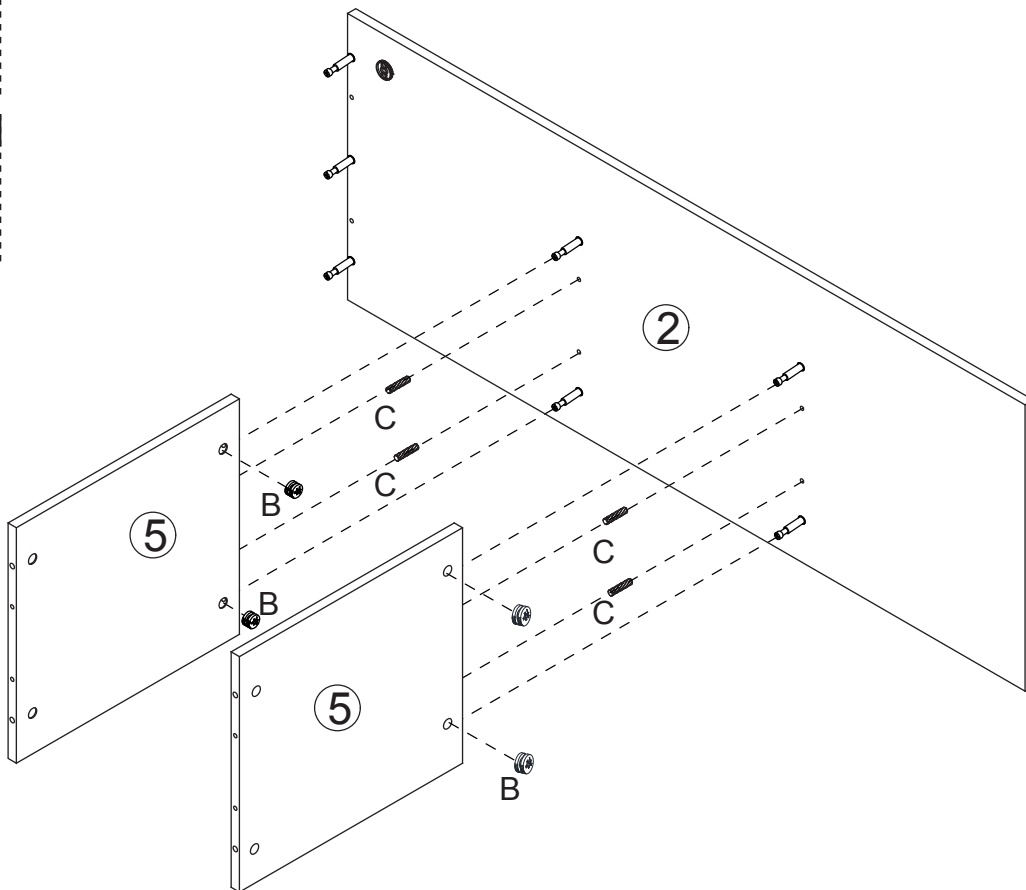

A x2



C x4

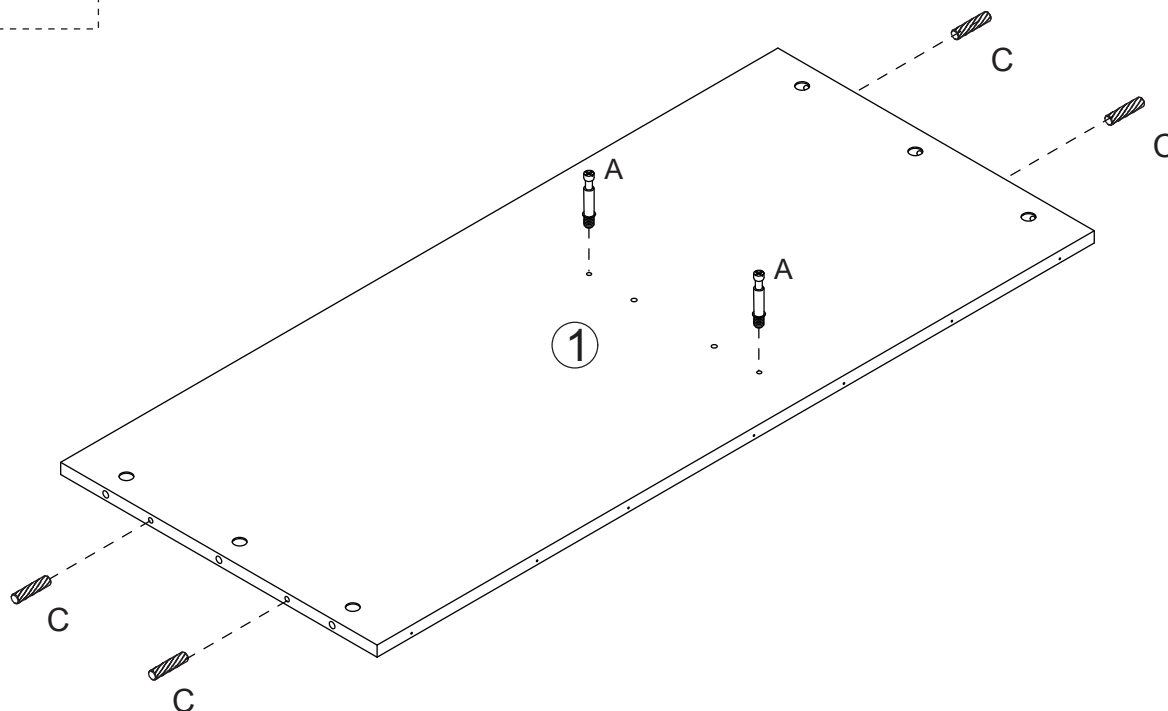

B x2



C x2

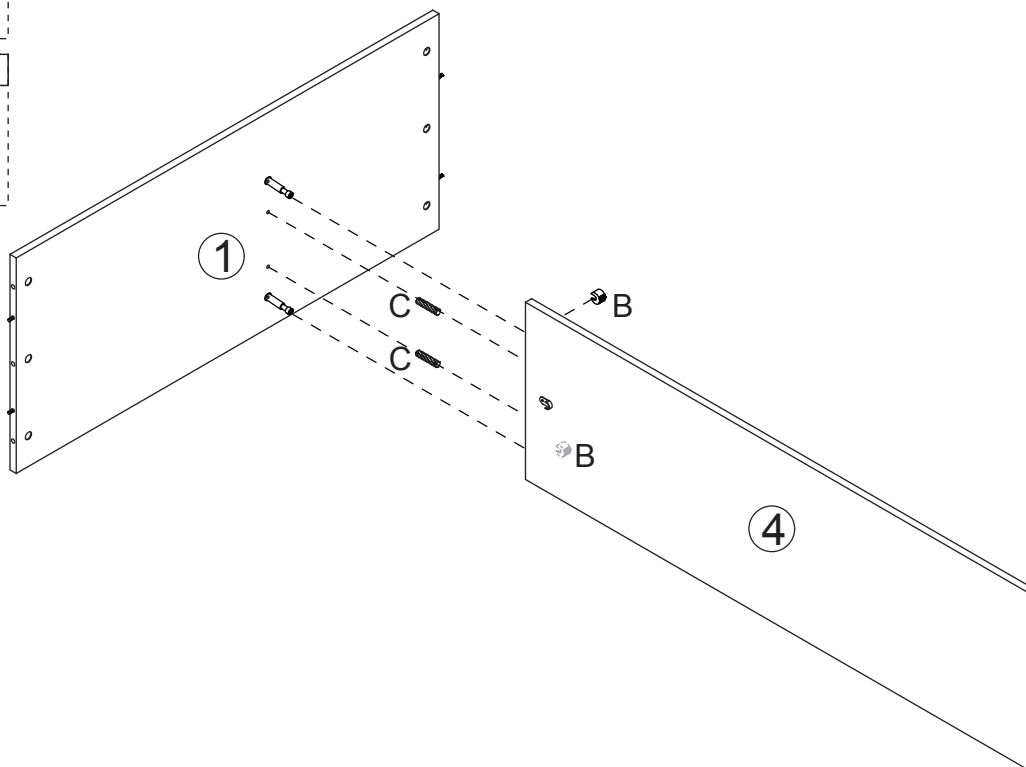

B x7



C x4

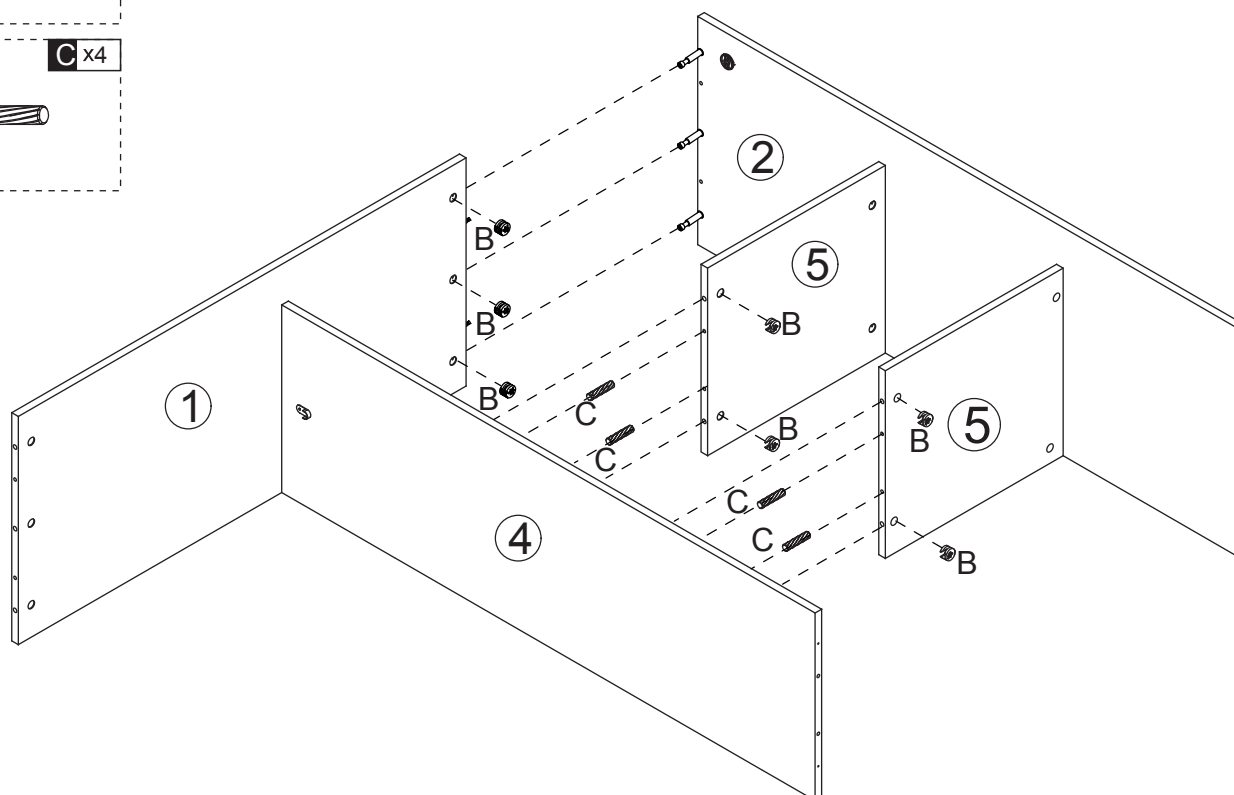

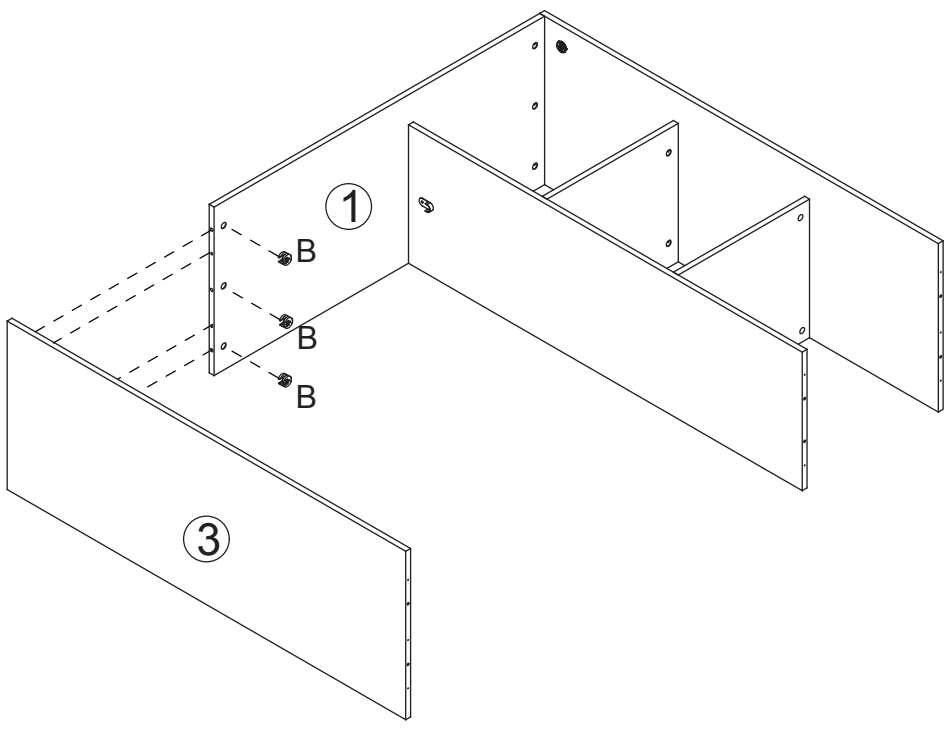
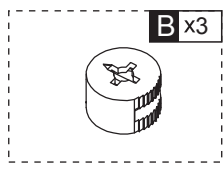
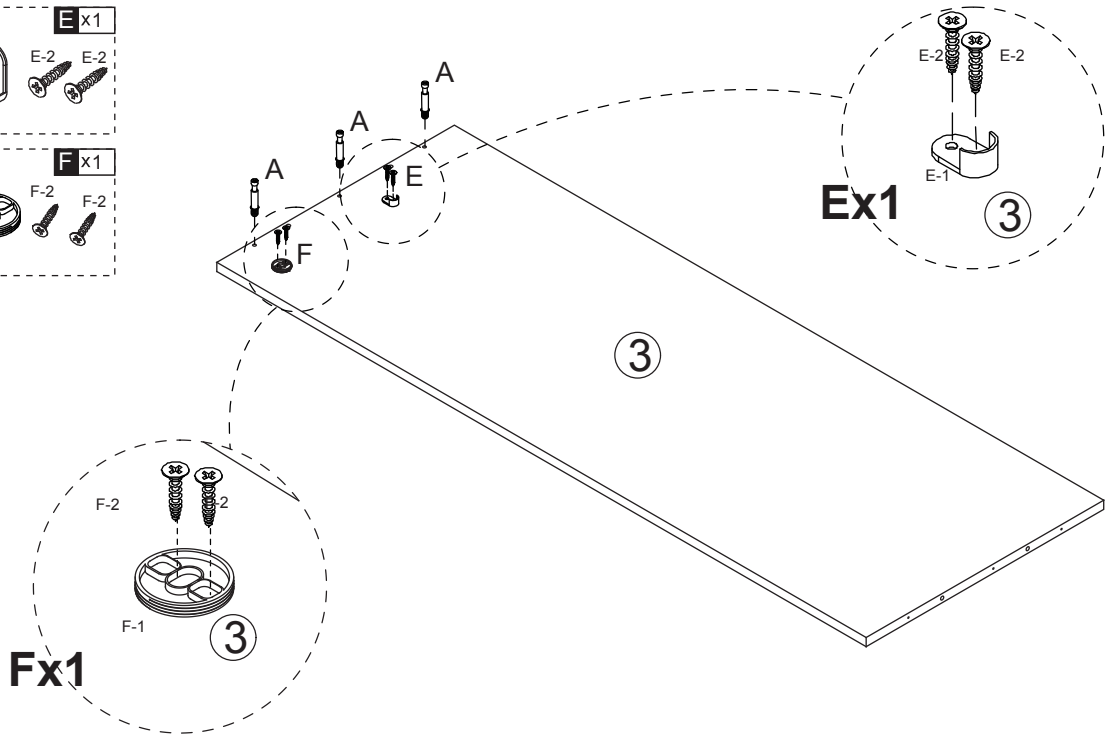
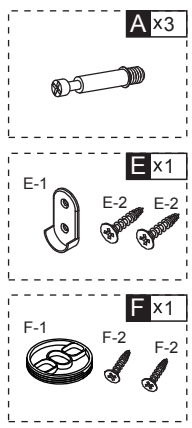

A x12

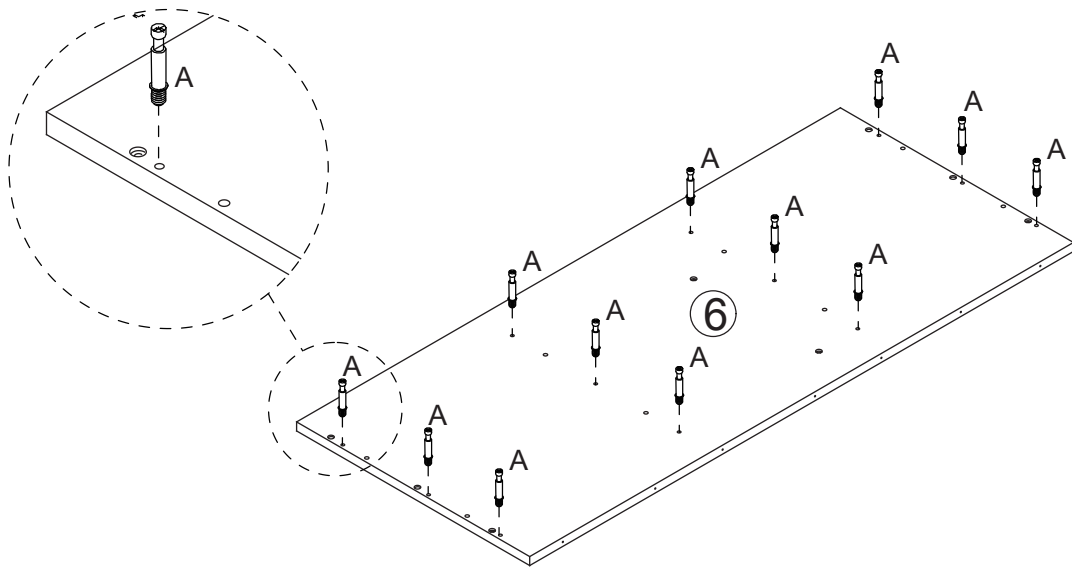
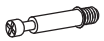

C x6



D x8

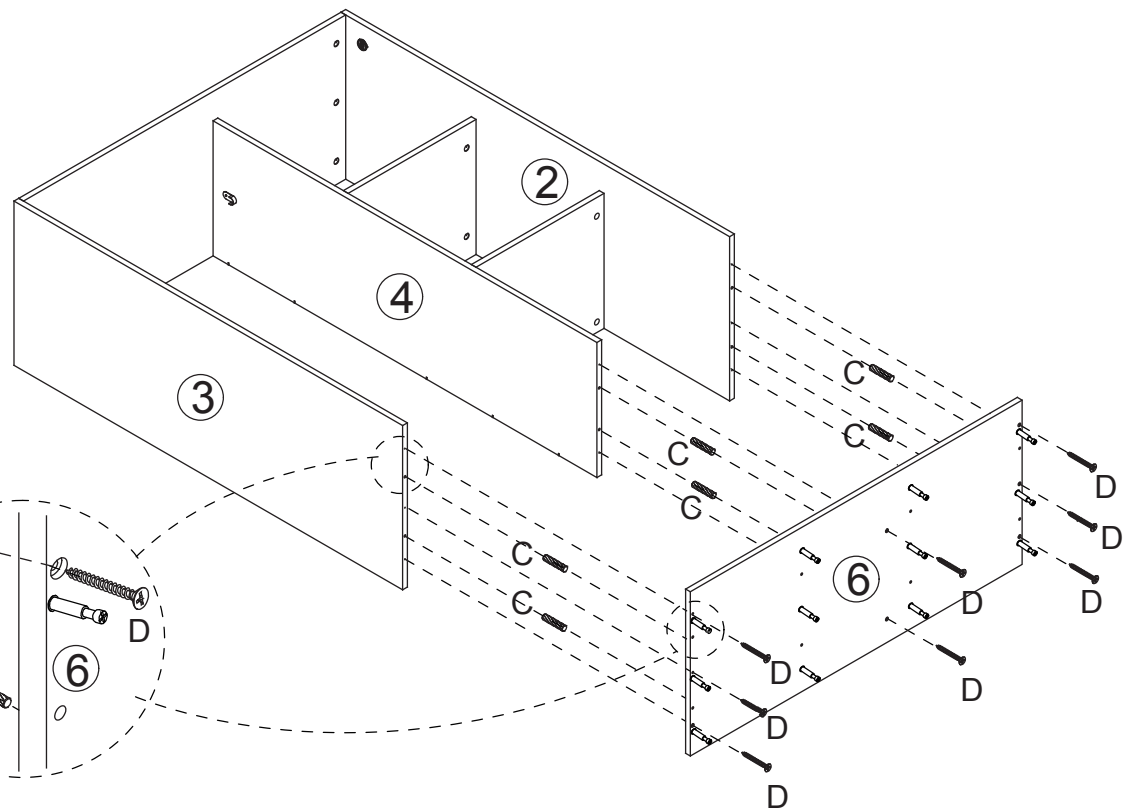

C x8

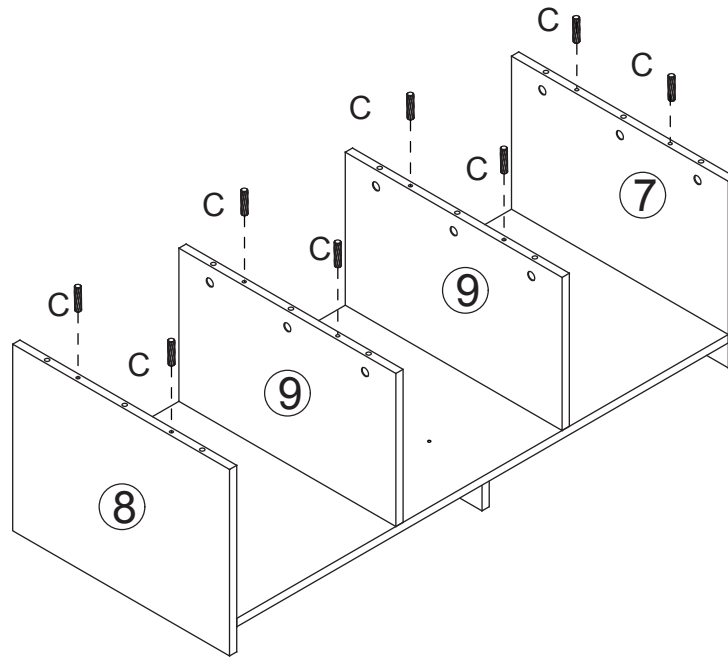

B x12

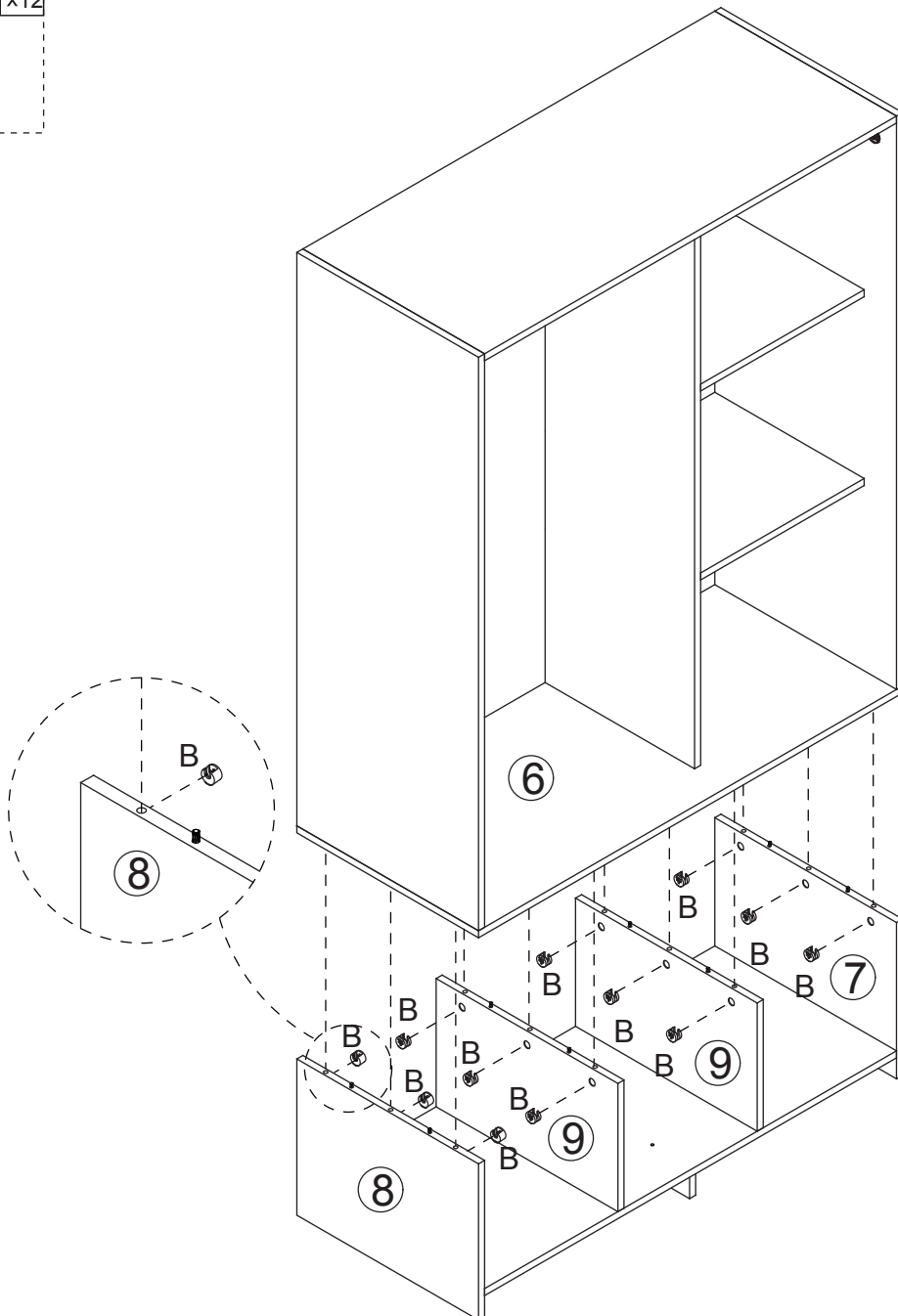

J x2

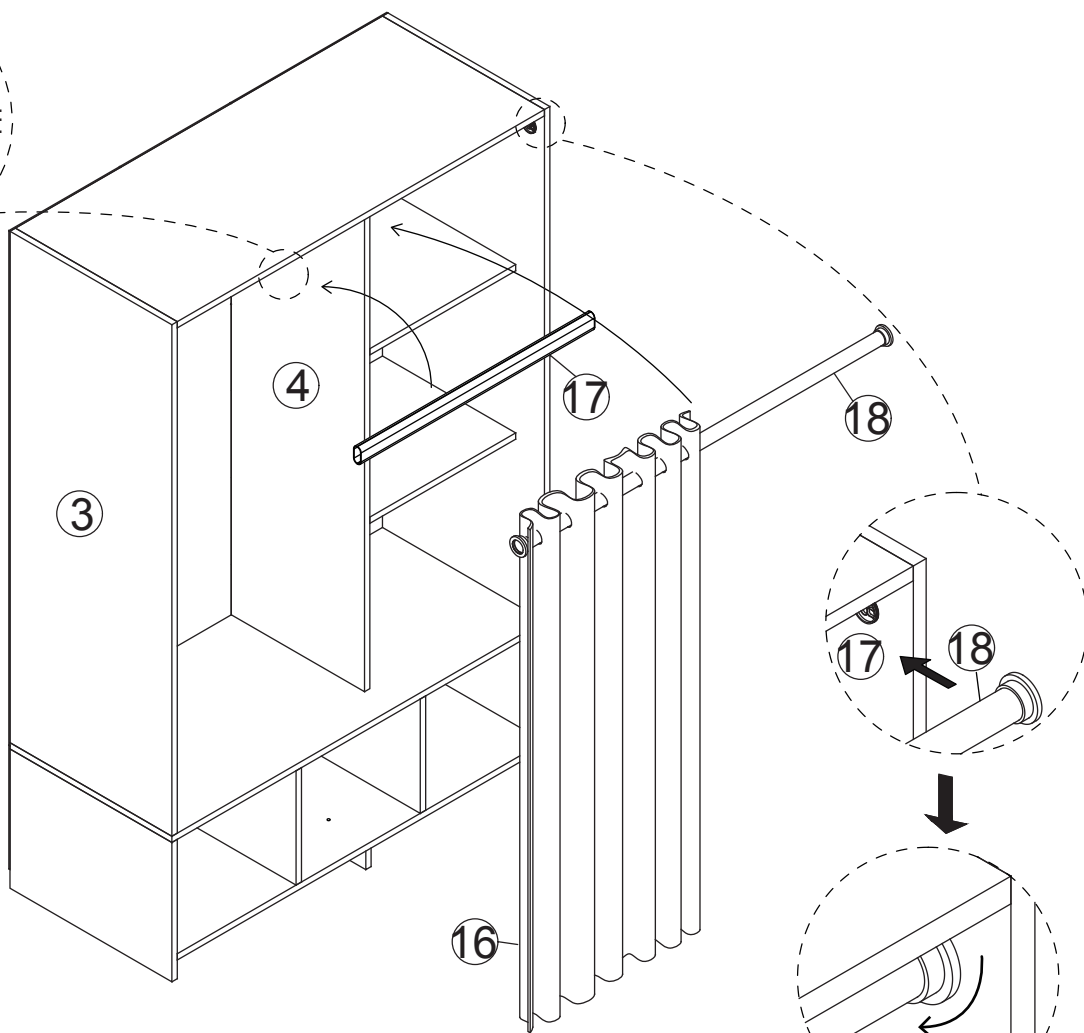
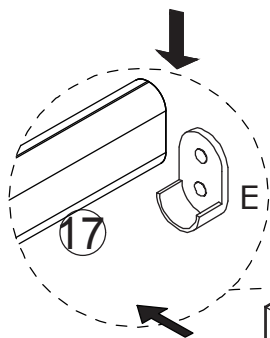
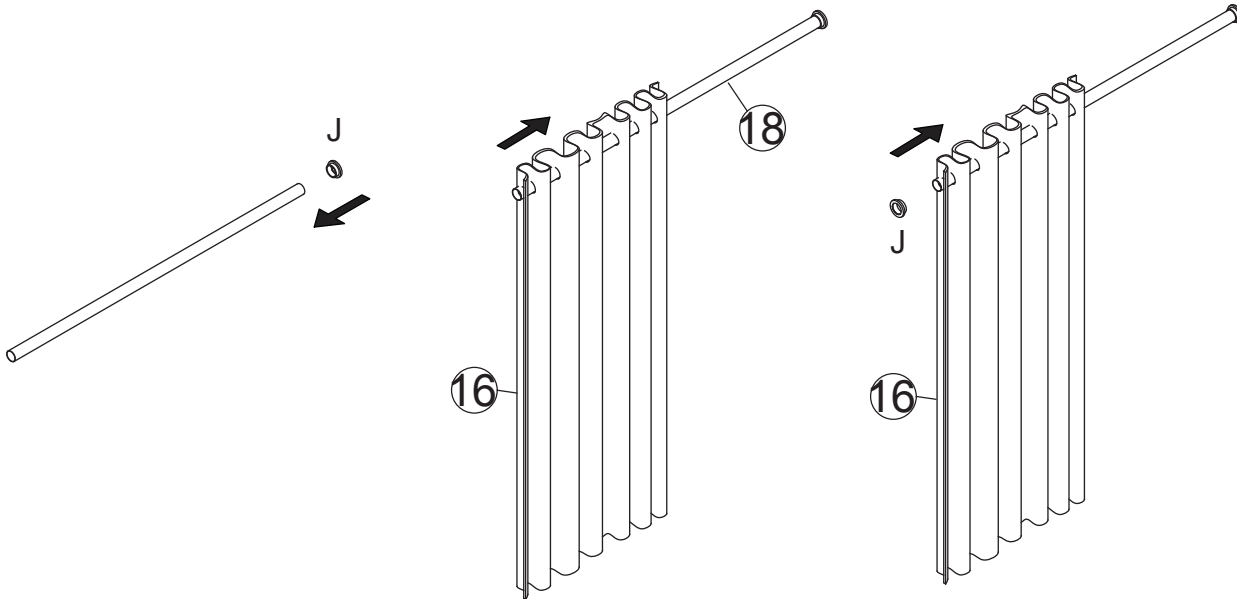

x3

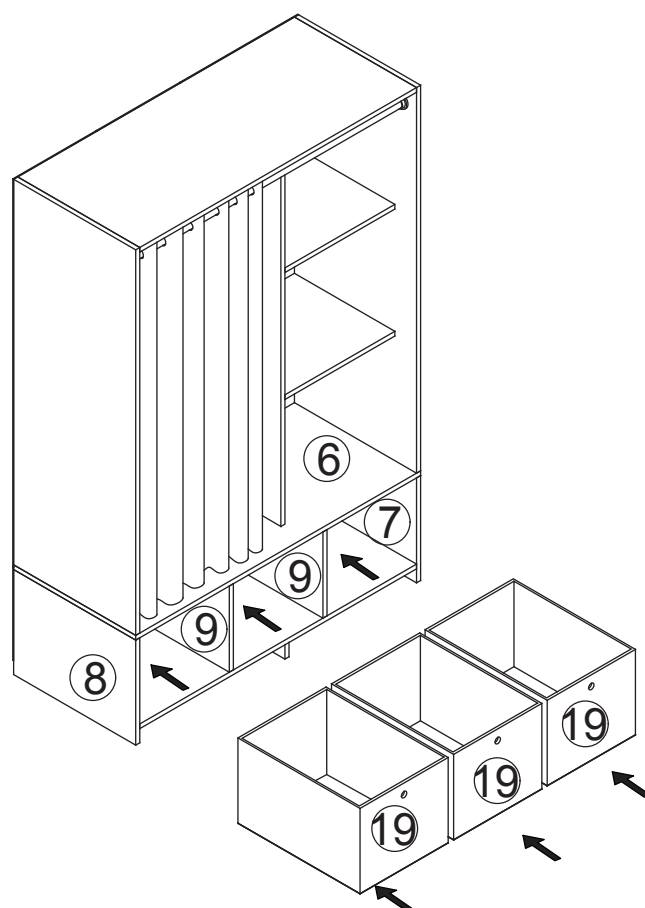
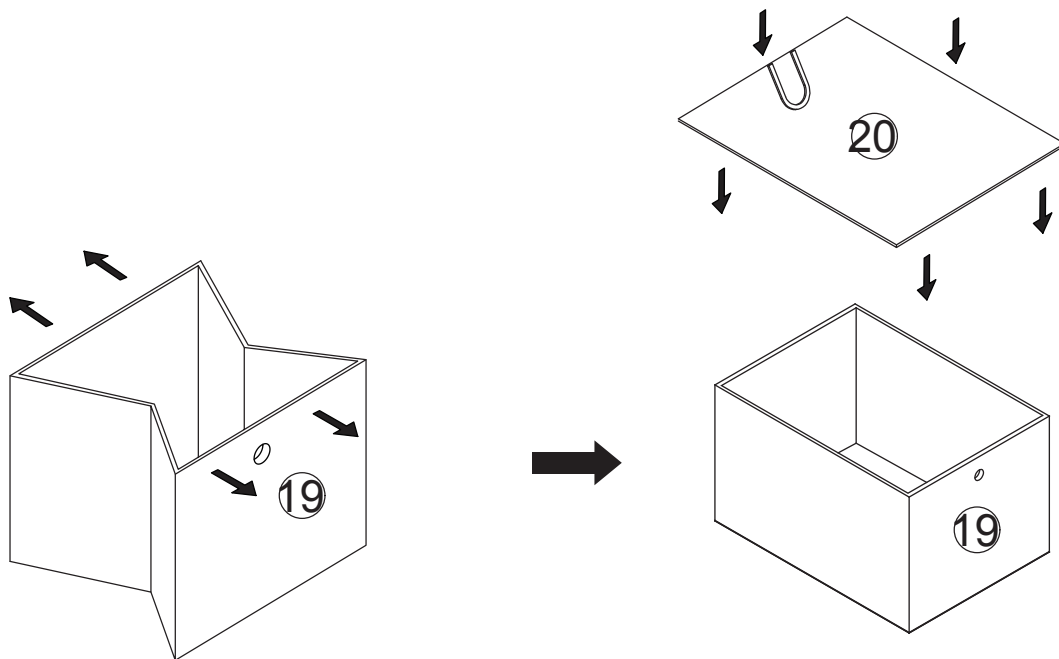

Gx39



Hx 2

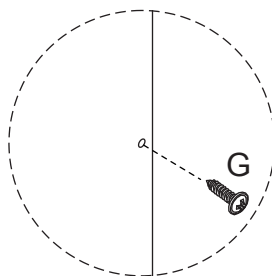
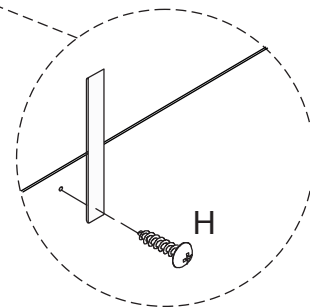
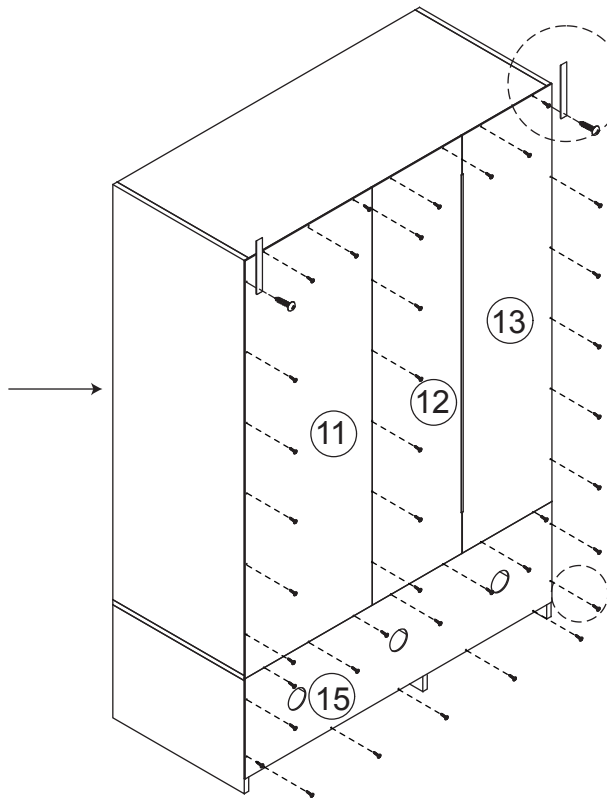
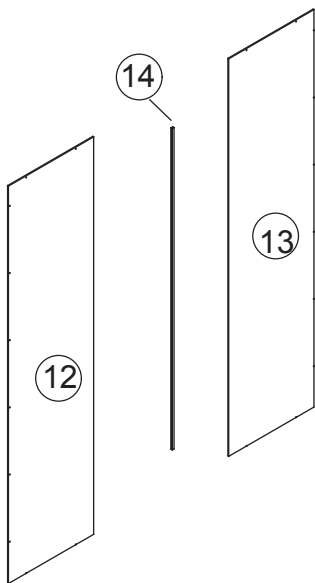

Ix 2



This is anti-dumping belt that fix the product to the wall and it can be used or not follow your needs.

If it is a solid wall, please use expansion and self-tapping screws, if it is a wooden wall, only use self-tapping screws, please do not overtighten the screws

